



ARMANI/CASA

ARMANI / CASA



LIMITED EDITIONS	5
INDOOR	13
UPHOLSTERED	20
CHAIRS	40
TABLES	50
BEDS	78
DESKS	88
BOOKCASES	92
CABINETS	94
OCCASIONAL	102
OUTDOOR	109
LIGHTING	129
RUGS & MATS	165
MATERIALS	191
INDEX	208



THE BRAND

Inseparably linked to all the other Armani brands, Armani/Casa provides a platform to express Giorgio Armani's vision of interiors: intimate special places with a mood of emotional pleasure, somewhere to relax and entertain guests surrounded by beauty and elegance.

The purpose of the Armani/Casa research is to communicate an atmosphere, to dress everyday living spaces in the same way Armani fashion creations dress people.

The Armani/Casa aesthetic philosophy focuses on simple lines and perfect proportions, enriched by precious materials, refined finishes, and elegant textiles.

The quest for sophisticated comfort turns into the creation of a total home setting, which uses a modern and rational design language.

Inspirations from Art Déco and Eastern cultures blend with contemporary influences, in a constant dialogue with the world of fashion.

Today Armani/Casa offers a complete range of products for home furnishing: from furniture to accessories, from fabrics to wallcoverings, from kitchen systems to bathroom concepts.



LIMITED EDITIONS



Limited Editions occupy a special place within the Armani/Casa collection. They are exceptional numbered pieces featuring even more precious finishes and details that express the ultimate luxury. Each Limited Edition features a metal tag with the progression number and Giorgio Armani's signature.

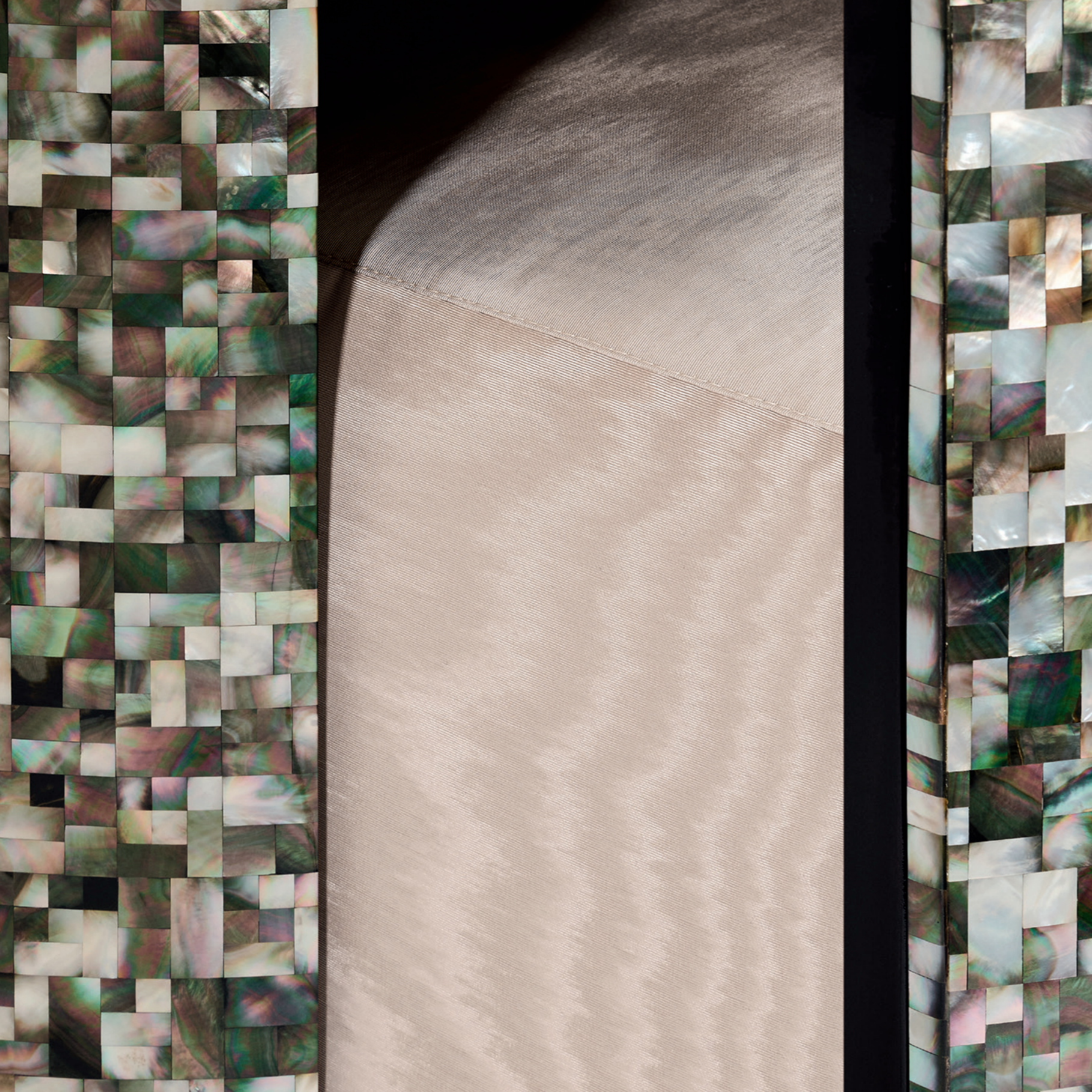

ANTOINETTE

The iconic *Antoinette* vanity table is characterized by a cylindrical shape with folding top and hidden seat. This version features the same backlit round mirror introduced in 2022, which can be turned on/off thanks to the central switch button and is dimmable. The outer structure stands out for its marvelous Shell Mosaic, entirely handmade with squared and rectangular mother-of-pearl tiles that enhances even more the preciousness of this piece. Inside, glossy Black Maple creates a beautiful contrast with the outer finish. The seat is upholstered with the *Tolosa* fabric (ERO69 - Pearl), showing a *moiré* design that highlights the connection with fashion collections by Giorgio Armani. *Antoinette* is a Limited Edition of 11 pieces. MADE IN ITALY.

DIMENSIONS

Closed: Ø 70x89,5h cm - Inch Ø 27.5x35.2h

LIGHT TEMPERATURE

3000 kelvin

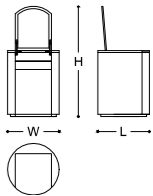

CODE: 045609 CH999 C3810

FINISHES



SHELL MOSAIC /
BLACK MAPLE /
TOLOSA FABRIC (ERO69 - PEARL)



ROYAL

Bar cabinet in Limited Edition, 88 pieces. *Royal* is a hand-crafted cabinet marked by details reminding a revisited *secrétaire* with shutter closure. The structure is marked by an elongated cylindrical shape with semicircular sides, which become also the base of the furniture. The bar unit is closed by two flexible doors that slide horizontally into the main structure, unveiling the working area completed by shelves and a large drawer for preparation tools. Always keeping a strong connection to Oriental influences and fashion inspirations, the cabinet is clad in a special weaving of paper and cotton reminiscent of a Japanese *tatami* and textured fabrics typical in Giorgio Armani's aesthetics. Inside, backlit panels of gold-toned methacrylate add movement thanks to their particular motif, recalling marble veins and mother of pearl. Metal details are in light brass with a satin finish.
MADE IN ITALY.

DIMENSIONS
150x60x160h cm - Inch 59x23.6x62.9h

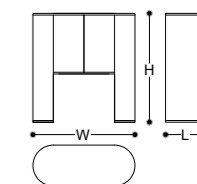

CODE: 050604 CH181 C0053

FINISHES



NATURAL-BLACK TATAMI /
SATIN LIGHT BRASS



INDOOR

UPHOLSTERED
CHAIRS
TABLES
BEDS
DESKS
BOOKCASES
CABINETS
OCCASIONAL



From upholstered products to chairs, from tables to beds, from desks to cabinets and occasionals: Armani/Casa offers a complete selection to furnish the living, dining and bedroom areas.

The pure design of the collection – combined with precious materials, rich textiles and a skillful use of colours and textures – creates the perfect atmosphere where to unwind with family and friends, surrounded by timeless beauty and elegance.



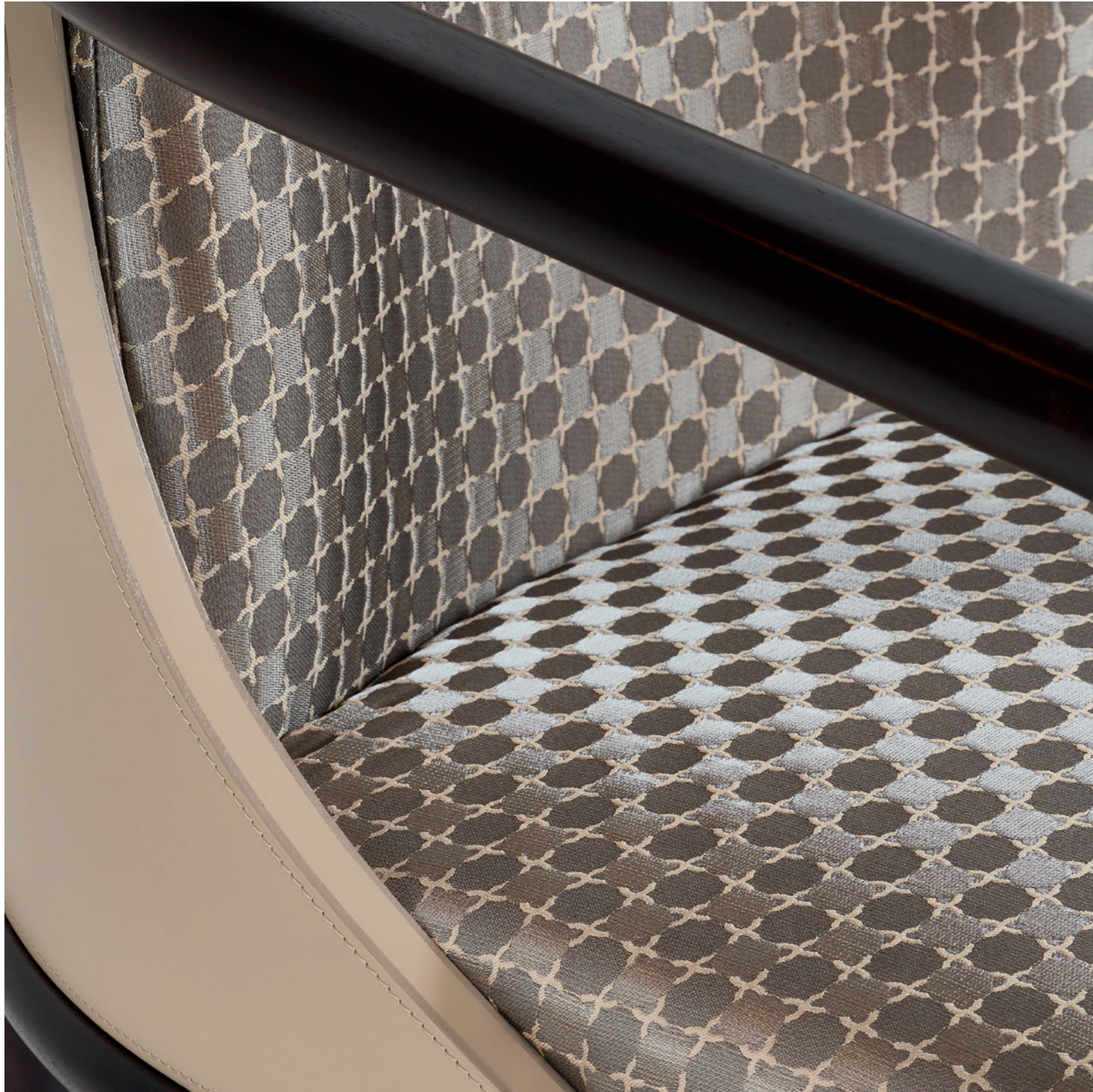

CANALETTO

Canaletto is a range with essential lines. The collection includes a two and three-seat sofa, a modular system, an armchair and a footrest. The system includes different elements that can be variously combined: a corner element, a one-seat element, a two-seat element (with or without right/left armrest) and a chaise-longue (with or without right/left armrest). Upholstery available in all suitable Armani/Casa fabrics or Soft Touch Leathers in collection. Fabric covers are removable. MADE IN ITALY.

DIMENSIONS

ARMCHAIR:

95x90x78h cm - 37.4x35.4x30.7h

2-SEAT SOFA:

224x105x78h cm - Inch 88.2x41.3x22.4h

3-SEAT SOFA:

314x105x78h cm - Inch 123.6x41.3x22.4h

2-SEAT ELEMENT:

180x105x78h cm - Inch 70.9x41.3x22.4h

2-SEAT ELEMENT (RIGHT/LEFT ARMREST):

202x105x78h cm - Inch 79.9x41.3x22.4h

SINGLE ELEMENT:

90x105x78h cm - Inch 35.4x41.3x22.4h

CHAISE LONGUE:

90x190x78h cm - Inch 35.4x74.8x22.4h

CHAISE LONGUE (RIGHT/LEFT ARMREST):

112x190x78h cm - Inch 44.1x74.8x23.6h

CORNER ELEMENT:

105x105x78h cm - Inch 41.3x41.3x22.4h

FOOTREST:

105x105x42h cm - Inch 41.3x41.3x16.5h

SH: 42 cm - Inch 16.5



CODE: 048015 CT00x / 048031 CT00x / 048029 CT00x / 048037 CT00x, FABRIC TO CHOOSE

Composition Units

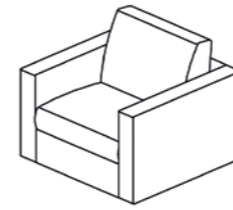

ARMCHAIR

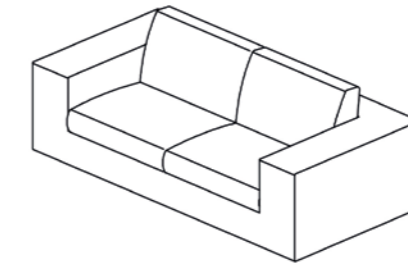

2-SEAT SOFA

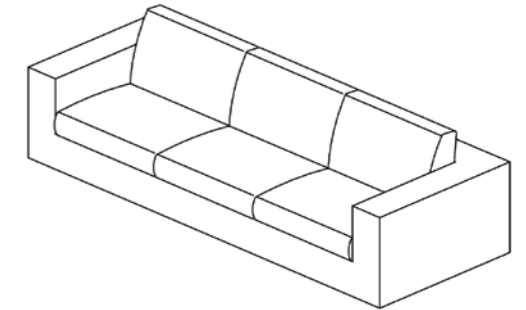

3-SEAT SOFA

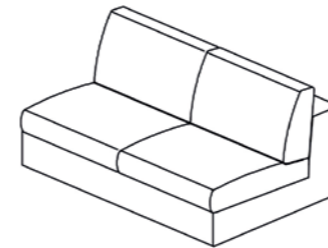

2-SEAT ELEMENT

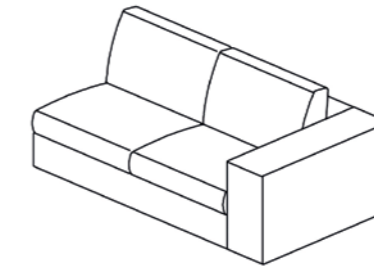

2-SEAT ELEMENT + RIGHT ARMREST

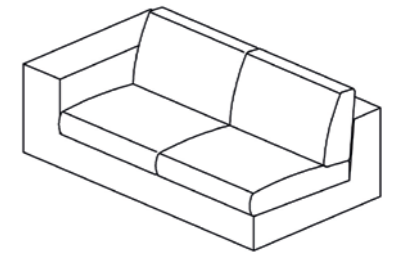

2-SEAT ELEMENT + LEFT ARMREST

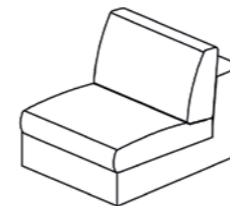

SINGLE ELEMENT

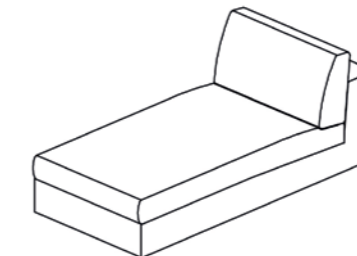

CHAISE LONGUE

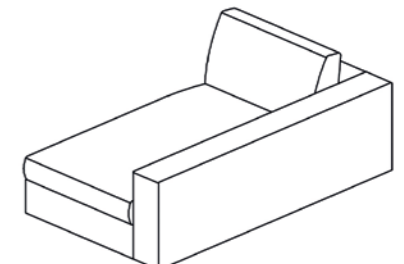

CHAISE LONGUE + RIGHT ARMREST

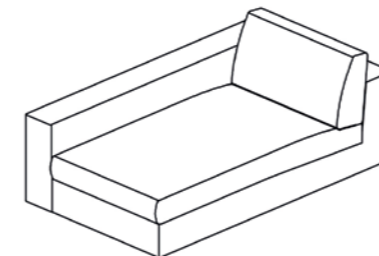

CHAISE LONGUE + LEFT ARMREST

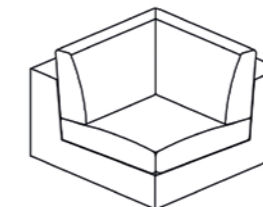

CORNER ELEMENT

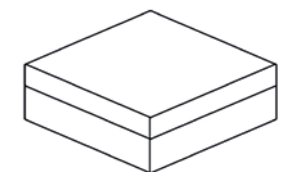

FOOTREST

OPEN

Open recalls the neat aesthetics typical of Armani/Casa. Conceived to be classic yet contemporary pieces, all modules - corner, footrest and keystone element excluded - of this sofa are available also with a sliding seat to become even more comfortable. A monolithic recessed base lifts the seat from the ground. Since all modules host one seat only, Open can be customized in many different ways to create linear, angular and curved compositions, suitable for any living room. The keystone sectional element is available in unique size with an angle of 45°. This range can be upholstered with all fabrics and Soft Touch Leathers in collection; fabric covers are removable. Open includes a rectangular footrest that can also serve as a modular element, along with a bridge table/tray in leather (cuoio) featuring visible stitching, as a complementary accessory. MADE IN ITALY.

DIMENSIONS

ARMCHAIR:

91x85x72h cm - Inch 35.8x33.5x28.3h

SINGLE ELEMENT - WITH OR WITHOUT SLIDING SEAT:

90x110x75h cm - Inch 35.4x43.3x29.5h

SINGLE ELEMENT - WITH OR WITHOUT SLIDING SEAT (RIGHT/LEFT ARMREST):

120x110x75h cm - Inch 47.2x43.3x29.5h

CORNER ELEMENT:

110x110x75h cm - Inch 43.3x43.3x29.5h

KEYSTONE ELEMENT:

140x110x75h cm - Inch 55.1x43.3x29.5h

FOOTREST:

90x110x42h cm - Inch 35.4x43.3x16.5h

60x110x42h cm - Inch 23.6x43.3x16.5h

SH: 43 cm - Inch 17

TABLE/TRAY:

62x40x15h cm - Inch 24.4x15.7x5.9h



CODE: 051219 CT00C ER186 / 050180 CT00C ER186 / 050186 CT00C ER186, ATLANTA FABRIC

Composition Units

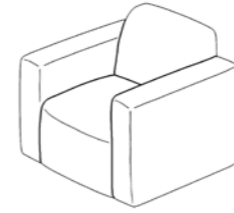

ARMCHAIR

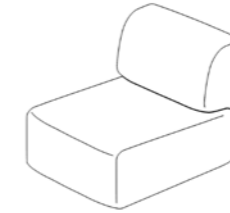

SINGLE ELEMENT

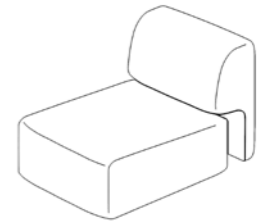

SINGLE ELEMENT WITH SLIDE

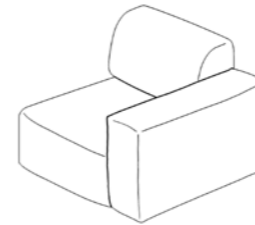

SINGLE ELEMENT + RIGHT ARMREST

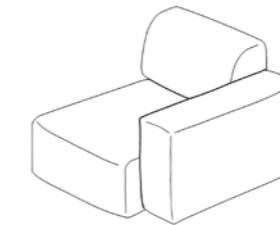

SINGLE ELEMENT WITH SLIDE + RIGHT ARMREST

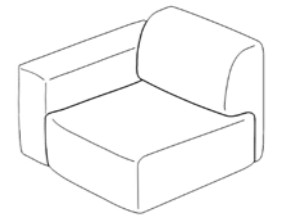

SINGLE ELEMENT + LEFT ARMREST

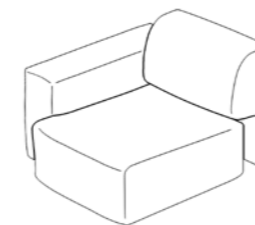

SINGLE ELEMENT WITH SLIDE + LEFT ARMREST

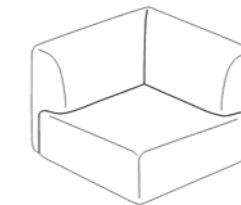

CORNER ELEMENT

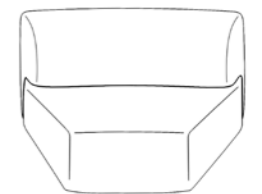

KEYSTONE ELEMENT

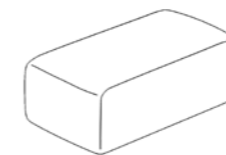

FOOTREST

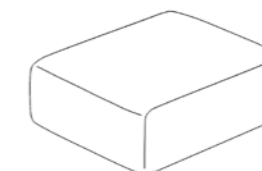

FOOTREST

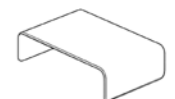

TABLE/TRAY

ORSON

Orson offers a wide variety of options, since it includes different freestanding pieces as well as a complete modular system. All elements are marked by sinuous lines. Upholstery available in all suitable fabrics or Soft Touch Leathers in collection. Covers in fabric are removable. MADE IN ITALY.

DIMENSIONS

2-SEAT:
190x105x80h cm - Inch 74.8x41.3x31.4h

2-SEAT LARGE:
230x105x80h cm - Inch 90.5x41.3x31.4h

3-SEAT:
270x105x80h cm - Inch 106.2x41.3x31.4h

2-SEAT ELEMENT (RIGHT/LEFT ARMREST):
175x105x80h cm - 68.8x41.3x31.4h

3-SEAT ELEMENT (RIGHT/LEFT ARMREST):
255x105x80h cm - Inch 100.4x41.3x31.4h

CHAISE-LONGUE (RIGHT/LEFT ARMREST):
105x255x80h cm - Inch 41.3x100.3x31.4h

SH: 44 cm - Inch 17.3



CODE: 050166 CT00x / 050167 CT00x, FABRIC TO CHOOSE

Composition Units

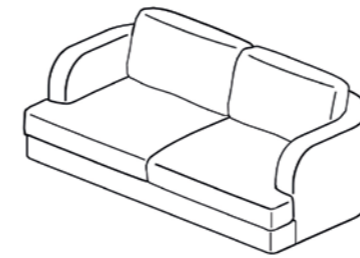

2-SEAT SOFA

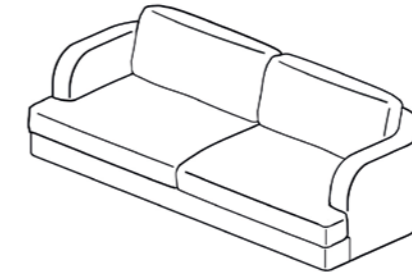

2-SEAT LARGE SOFA

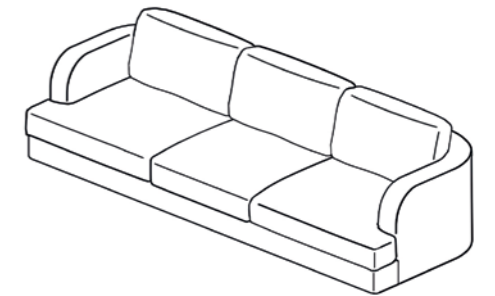

2-SEAT SOFA

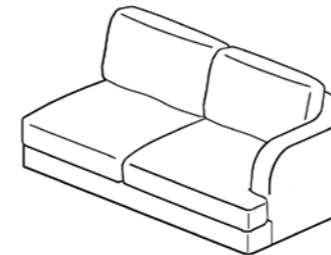

2-SEAT ELEMENT + RIGHT ARMREST

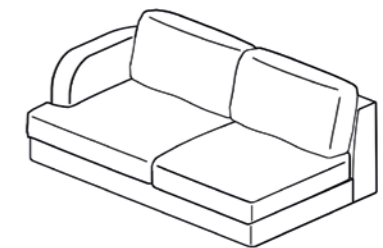

2-SEAT ELEMENT + LEFT ARMREST

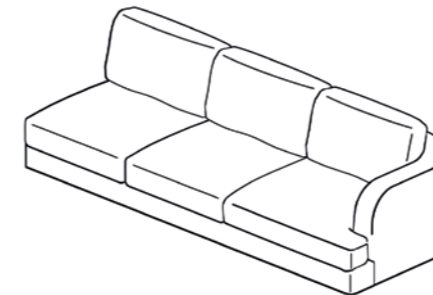

2-SEAT ELEMENT + RIGHT ARMREST

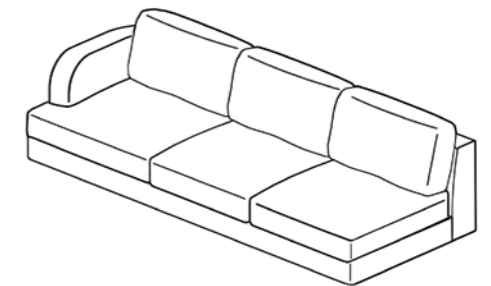

2-SEAT ELEMENT + LEFT ARMREST

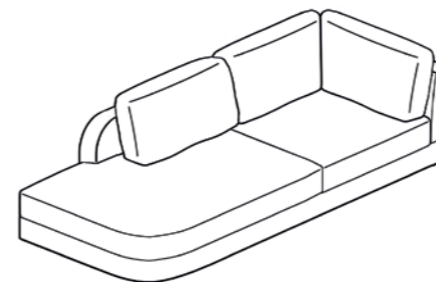

CHAISE LONGUE + LEFT ARMREST

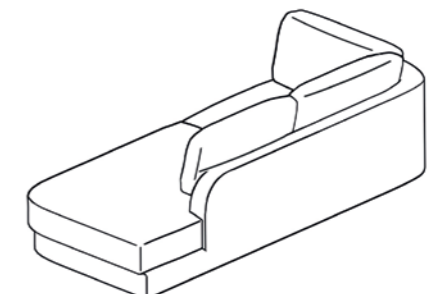

CHAISE LONGUE + RIGHT ARMREST

ALBERT

Albert is a three-seat sofa marked by a classic design with rigorous lines. It presents three separated seat cushions, as well as divided backrest cushions. Feet are in solid Canaletto Walnut. *Albert* can be upholstered with all suitable Armani/Casa fabrics or Soft Touch Leathers in collection. Fabric covers are removable. MADE IN ITALY.

DIMENSIONS

3-SEAT:

272x96x86h cm - Inch 107x37.8x33.8h

SH: 39 cm - Inch 15.4

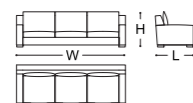

FINISHES

CANALETTO WALNUT



CODE: 051990 CT00C ER200, ADDA FABRIC

RENOIR

Renoir is an upholstered sofa with rounded shape and solid wood feet (10 cm high). The concepts of extreme coziness and relax are the main inspirations of this piece, marked by curved volumes and the unique seating cushion. *Renoir* can be placed at the center of the room, where it can become the focal point of the setting especially if matched with other rounded armchairs and footrests. Available in all fabrics and Soft Touch Leathers in collection. Covers are not removable. MADE IN ITALY.

DIMENSIONS

2-SEAT:

240x93x84h cm - Inch 94.4x36.6x33.1h

SH: 42 cm - Inch 16.5

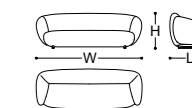

FINISHES

BRUSHED BLACK ASHWOOD



CODE: 050581 CT00C TX105, OULU FABRIC

VISO

Range comprising a sofa, a footrest and an armchair (to be bought separately). The sofa, available in two dimensions, is conceived as a protagonist piece, to be placed in the middle of the room. Thanks to its silhouette, Viso can be easily matched with other small ottomans part of the Armani/Casa collection, such as footrests and armchairs. The enveloping shape has been designed to ensure comfort in both relax and conversation settings. Viso can be upholstered with bi-elastic fabrics only. MADE IN ITALY.

DIMENSIONS

2-SEAT:
220x115x79h cm - Inch 86.6x45.2x31.1h

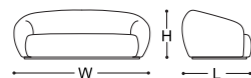

3-SEAT:
270x110x82h cm - Inch 106.3x43.3x32.3h



SH: 40 cm - Inch 15.7

FOOTREST:
115x65x35h cm - Inch 45.2x25.6x13.7h

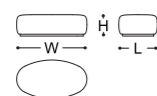

CODE: 051226 CT00C TX107, OULU FABRIC

FINISHES

PLATINUM LACQUER

VISO

Part of the range that includes a sofa and a footrest (each sold separately), the Viso armchair is designed to offer both comfort and style. Its enveloping silhouette ensures a cozy seating experience, ideal for both relaxation and conversation. Viso can be upholstered with bi-elastic fabrics only. MADE IN ITALY.

DIMENSIONS

100x91x75h cm - Inch 39.3x35.8x29.5h

SH: 40 cm - Inch 15.7

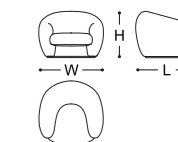

CODE: 051225 CT00C ER162, ANTARCTICA FABRIC

FINISHES

PLATINUM LACQUER

SHARON

The Sharon range features a two-seat sofa, to match the armchair and the footrest with the same name. All those products share the same concept of the Morfeo bed and the Onda chaise-longue : the inspiration comes from the idea of a folded paper sheet, creating a sinuous silhouette in a single piece. Sharon is available in two different finishes. The version in Brushed Honey Ashwood and Hazelnut Midollino features a band in Cognac Thin Leather on the back of the backrest and can be upholstered with all suitable Armani/Casa fabrics and Soft Touch Leathers in collection. The version in Canaletto Walnut and Dove Grey Thin Leather, instead, is upholstered with Siracusa in Platinum colour: a fabric showing a materic effect created by a mix of different yarns (viscose, cotton, polyester, linen) playing around the same palette. Fabric covers are removable. MADE IN ITALY.

DIMENSIONS

2-SEAT:

160x82x77h cm - Inch 62.9x32.2x30.3h

SH: 45 cm - Inch 17.7

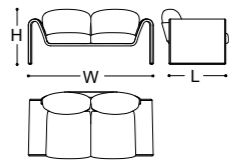

FINISHES



* CODE: 050799 CT00B TX191, TRENTO FABRIC

SHARON

Sharon is an armchair with footrest (to be bought separately), sharing the same concept of the Morfeo bed and the Onda chaise-longue: the inspiration comes from the idea of a folded paper sheet, creating a sinuous silhouette in a single piece. Sharon is available in two different finishes. The version in Brushed Honey Ashwood and Hazelnut Midollino features a band in Cognac Thin Leather on the back of the backrest and can be upholstered with all suitable Armani/Casa fabrics and Soft Touch Leathers in collection. The footrest of this version features a small cushion in fabric or Cognac leather. The version in Canaletto Walnut and Dove Grey Thin Leather is upholstered with Siracusa in Platinum colour: a fabric showing a materic effect created by a mix of different yarns (viscose, cotton, polyester, linen) playing around the same palette. Fabric covers are removable. MADE IN ITALY.

DIMENSIONS

ARMCHAIR:

90x82x77h cm - Inch 35.4x32.2x30.3h

SH: 45 cm - Inch 17.7

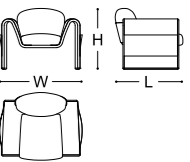

FOOTREST:

60x45x47h cm - Inch 23.6x17.7x18.5h

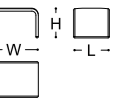

FINISHES



* CODE: 050711 CH965 ER048 (ARMCHAIR), 050767 CH965 C0554 (FOOTREST)

BORROMINI

Chaise-longue in Shiny Santos Rosewood that can be upholstered with all suitable Armani/Casa fabrics in collection. The curved lines are inspired by lounge furniture dating back to the early 20th century. With its eclectic look, *Borromini* is perfect to be used in a studio or in a relax area; it will create the perfect atmosphere in a sunroom, close to a fireplace or a bookcase. Covers are not removable. MADE IN ITALY.

DIMENSIONS
198x78x86,2h cm - Inch 78x30.7x33.9h
SH: 40,7 cm - Inch 16

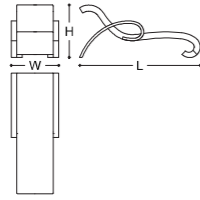

CODE: 045944 PAL0x, FABRIC TO CHOOSE

FINISHES

SHINY SANTOS ROSEWOOD

ONDA

The *Onda* chaise-longue takes inspiration from the *Morfeo* bed: both ranges were born from the idea of a folded paper sheet, creating a sinuous silhouette made with a unique piece. The frame of the chaise-longue is made with solid wood, while the central part is covered with different materials depending on the version. *Onda* is equipped with a thin mattress and a movable cushion upholstered with fabric, in a colour matching the main material of the structure. MADE IN ITALY.

DIMENSIONS
185x80x85h cm - Inch 72.8x31x33.4h
SH: 35 cm - Inch 13.7

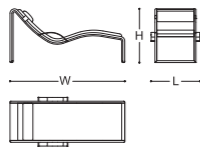

* CODE: 050112 CA941 ER003, MELBOURNE FABRIC

FINISHES

CANALETTO WALNUT / DARK GREEN INTERWOVEN LEATHER / MELBOURNE FABRIC (ER003 - MINT) *

CANALETTO WALNUT / JAPAN RED SOFT TOUCH LEATHER / SINGAPORE FABRIC

CANALETTO WALNUT / TECHNICAL CHINCHILLA FABRIC / LUXEMBOURG FABRIC (TR814 - IVORY)

PRETTY

Dedicated to cinema actresses from the Twenties and the Thirties, the *Pretty* dormeuse was conceived as a hero piece to be placed centrally in a room, thanks to its curved lines that can be admired from all perspectives; the rounded shapes are made lighter by the wide empty space below the seat. The off-centered backrest - available both in right and left option - makes this charming piece of furniture suitable for being used also as a small sofa. Available in all Armani/Casa fabrics and Soft Touch Leathers in collection; covers are not removable. MADE IN ITALY.

DIMENSIONS
208x88x75h cm - Inch 81.9x34.6x29.5h
SH: 44 cm - Inch 17.3

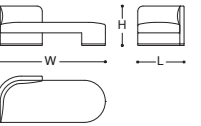

* CODE: 050892 CT00E ER081, TOLEDO FABRIC

FINISHES

HAZELNUT MIDOLLINO / SATIN LIGHT BRASS *

PLATINUM LACQUER **

** CODE: 050383 CT00D ER180, ALLURE FABRIC

RONDÒ

Rondò is an armchair characterized by an enveloping shape, thanks to its curved design. The backrest creates a single element with the rounded armrests. On the back view, the armchair shows a peculiar – almost spherical – silhouette. Given these unique features, Rondò can easily become the focal point of a room. The armchair rests on a slightly recessed lacquered base, on which it can rotate. Upholstery is not removable and is available in Soft Touch Leather or in bi-elastic fabrics (*Antarctica*, *Oulu* and *Tel Aviv*).
MADE IN ITALY.

DIMENSIONS

86x80x78h cm - Inch 33.8x31.5x30.7h

SH: 40 cm - Inch 15.7

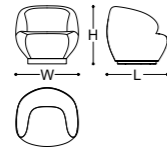

CODE: 050650 CT00B ER102, TEL AVIV FABRIC

FINISHES

PLATINUM LACQUER

ESSEX

Armchair with enveloping shape, thanks to the curved armrests in multidensity foam. Available in two sizes. Visible wooden feet. Essex can be upholstered with all suitable Armani/Casa fabrics or Soft Touch Leathers in collections. Fabric covers are removable.
MADE IN ITALY.

DIMENSIONS

REGULAR:

82x87x67h cm - Inch 32.3x33.9x26.4h

LARGE:

90x90x67h cm - Inch 35.4x35.4x26.4h

SH: 39 cm - Inch 15.3

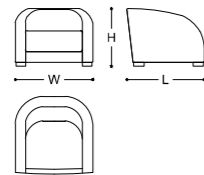

CODE: 045492 RMA0x (LARGE), FABRIC TO CHOOSE

FINISHES

BRUSHED BROWN OAK

BALOON

Tubular armchair and footrest, to be bought separately. These iconic pieces draw inspiration from the style of the 30s. The visible metal structure is in Satin Black Nickel. Upholstery is not removable and available in the bi-elastic fabrics *Antarctica* and *Oulu*. *Baloon* can easily become the focal point of a room thanks to its attractive design and vintage touch.
MADE IN ITALY.

DIMENSIONS

ARMCHAIR:

87x92x67h cm - Inch 34.3x36.2x26.3h

SH: 40 cm - Inch 15.7

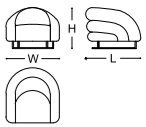

FOOTREST:

80x80x36,5h cm - Inch 31.5x31.5x14.4h

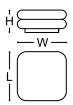

CODE: 045938 CT00C TX105, OULU FABRIC



CODE: 048117 CT00C TX105, OULU FABRIC

FINISHES

SATIN BLACK NICKEL

PAUL

The *Paul* armchair takes inspiration from seats typical of the 30s and the 40s, immediately recalling the aesthetics of gents' clubs of that time. Armani/Casa modernizes this classic design by adding updated details, like a higher seat and revised proportions. A distinctive feature of this piece is the presence of visible vertical stitchings on the seatback, which create almost a *matelassé* effect reminiscent of collectors' cars of the early XX century. Inner structure of seat and seatback with springs in harmonic steel; four thin squared feet in solid wood. Upholstery available in all Armani/Casa fabrics and Soft Touch Leathers in collection, plus a special Beige Vintage Leather developed exclusively for this range. Covers are not removable.
MADE IN ITALY.

DIMENSIONS

98x96x77h cm - Inch 38.5x37.7x30.3h

SH: 42,5 cm - Inch 16.7

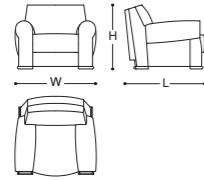

CODE: 050353 CH039 C3055, BEIGE VINTAGE LEATHER

FINISHES

CANALETTO WALNUT

TOKYO

Armchair with structure in wood and in multi-density polyurethane foam. Feet in solid brown oak. It can be upholstered with all suitable Armani/Casa fabrics or Soft Touch Leathers in collection. Fully removable fabric covers.
MADE IN ITALY.

DIMENSIONS

84x93x62h cm - Inch 33.1x36.6x24.4h

SH: 45 cm - Inch 17.7

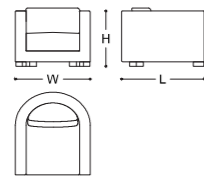

CODE: 045088 RMAOC TX126, PALERMO FABRIC

FINISHES

BRUSHED BROWN OAK

PASCAL

The *Pascal* armchair is marked by its curved design, where the armrests are created by the prosecution of the seatback itself. The enveloping shape is not imposing at all, making this armchair ideal for small spaces/corners and for the contract sector as well. Another feature of this piece is the presence of four feet in solid wood. The inner structure of the seat features springs in harmonic steel, while the seatback presents a rubber padding. Due to its curved lines, *Pascal* can be subject to limitations when choosing the upholstery: the upholstery is hence available in all Armani/Casa fabrics suitable for this kind of shape, plus all Soft Touch Leathers in collection. This armchair is available in a special Brown Vintage Leather developed for this range only. Covers are not removable.
MADE IN ITALY.

DIMENSIONS

80x83x70h cm - Inch 31.5x32.6x27.5h

SH: 40 cm - Inch 15.7

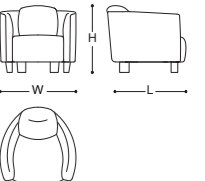

CODE: 050349 CH053 C0053, BROWN VINTAGE LEATHER

FINISHES

CANALETTO WALNUT

GARDENIA

Gardenia is an upholstered bench that can either be used as an end-of-bed bench or singularly inside a room. Thanks to its neutral design it can easily be placed with all kinds of beds. Completely padded and upholstered, this bench is marked by its frame kept above ground by two metal x-shaped bases, characteristic in the Armani/Casa design line: the same base structure, in fact, can be found on *Club*, *Damasio* and *Oreste*. Upholstery in all suitable Armani/Casa fabrics or Soft Touch Leathers; fabric covers are removable.
MADE IN ITALY.

DIMENSIONS

170x45x48h cm - Inch 66.9x17.7x18.9h

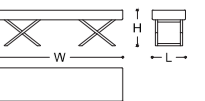

* CODE: 048543 CT00A ER068, TUCSON FABRIC

FINISHES

BRUSHED BROWN OAK

SMOKED GOLD *

GLAM

The *Glam* stool was born to complete the related coiffeuse and is available in a single size. It has a simple but functional design: the seat features curved sides and tubular metal legs with squared section. Differently from the matching coiffeuse, the stool can be upholstered with different materials - like all suitable Armani/Casa fabrics and Soft Touch Leathers in collection - becoming a multifunctional piece. Fabric covers are removable.
MADE IN ITALY.

DIMENSIONS
60x40x45h cm - Inch 23.6x15.7x17.7h

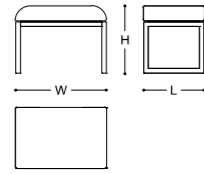

FINISHES

 SMOKED GOLD



CODE: 048546 CT00x, FABRIC TO CHOOSE

ROXY

Foldable stool in solid walnut and seat in thick leather (cuoio). The X-shaped legs move around a pivot enriched by the metal GA logo. From the side view, the legs show a structure made of several wooden laths. Roxy features tiny leather handles on the sides, to make the transport easier. Available in different leather (cuoio) colours.
MADE IN ITALY.

DIMENSIONS
48x42x42h cm - Inch 18.8x16.5x16.5h

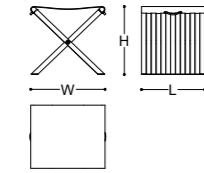

FINISHES

 CANALETTO WALNUT / SATIN LIGHT BRASS / LEATHER (CUOIO) TO CHOOSE



CODE: 050374 CA900 C0554

LAWRENCE

Rounded shape footrest. Available in two different sizes, large and small, that can be matched for several décor options. Upholstery available in all suitable Armani/Casa fabrics, Thin Leathers and Technical Shagreen Fabric. Base in bronze lacquer. Fabric covers are removable.
MADE IN ITALY.

DIMENSIONS
SMALL: 55x41x43h cm - Inch 21.7x16.1x17h
LARGE: 85x57x43h cm - Inch 33.5x22.4x17h

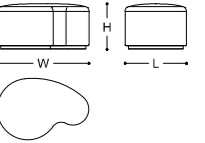

CODE: 048932 CT00B ER085 (LARGE), 048931 CT00B ER085 (SMALL), TASHKENT FABRIC

RODEO

The Rodeo range includes oval upholstered footrests/low stools available in two sizes. The main feature of this range is the tubular base – covered in thick leather (cuoio) and featuring metal details – that keeps those pieces lifted from the floor (6 cm). The large size is available in two versions, a fixed one and another that can be opened to access a container unit. Available in all fabrics and Soft Touch Leathers in collection. Covers are not removable.
MADE IN ITALY.

DIMENSIONS
SMALL:
60x40x43h cm - Inch 23.6x15.7x16.9h
LARGE (WITH OR WITHOUT CONTAINER):
85x50x43h cm - Inch 33.4x19.6x16.9h

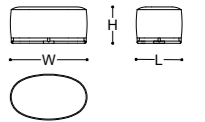

FINISHES

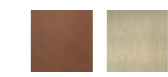
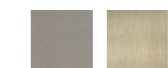
 COGNAC LEATHER (CUOIO) / SATIN LIGHT BRASS *
 CORTECCIA BROWN LEATHER (CUOIO) / SATIN LIGHT BRASS
 DOVE GREY LEATHER (CUOIO) / SATIN LIGHT BRASS



* CODE: 050658 CT00D TX163 (LARGE), 050657 CT00D TX163 (SMALL), RIVOLI FABRIC

AMBRA

Dining chair featuring a bi-material backrest: the outer shell is crafted in leather (cuoio), while the inner part is upholstered in fabric matching the seat. The part in leather presents a hole to be used as handle, in order to make the chair easier to move. Legs and armrests show a circular section and are in solid Canaletto Walnut. MADE IN ITALY.

DIMENSIONS

57x62,5x82h cm - Inch 22.4x54.6x32.3h

SH: 48 cm - Inch 18.9

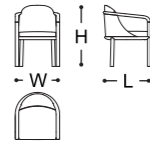

CODE: 051992 CT00C ER174, ASIA FABRIC

FINISHES

CANALETTO WALNUT / LEATHER (CUOIO) TO CHOOSE

LEA

Upholstered chair featuring a sinuous design, with large curved armrests and seatback to ensure higher comfort and ergonomics. Cantilever seat. Lea features a metal base in hand-polished brass with a height-adjustable structure; upholstery in all leathers available. MADE IN ITALY.

DIMENSIONS

60x72x86h cm - Inch 23.6x28.3x33.8h

SH:

min. 45/max. 51 cm - Inch min. 17.7/max. 20

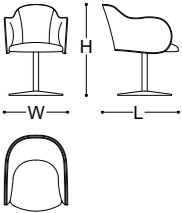

* CODE: 050590 CA900 C0586

FINISHES

SATIN LIGHT BRASS / LEATHER *

SATIN ROSE BRASS / SOFT TOUCH LEATHER

PEGGY

The Peggy range comes from the idea of an enveloping and light seat, inspired by the multi-faceted figure of Peggy Guggenheim. The sinuous lines carved in the solid wood define an elegant functional silhouette. The result is a chair with sculptural yet very feminine aesthetics, paying a tribute to the love the famous collector had for *avant-garde*. Upholstery available in all suitable Armani/Casa fabrics or Soft Touch Leathers in collection; covers are not removable. MADE IN ITALY.

DIMENSIONS

62x56x75h cm - Inch 24.4x22x29.5h

SH: 47 cm - Inch 18.5

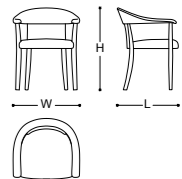

CODE: 051992 CT00C ER190, ARNO FABRIC



* CODE: 050355 NOC0x, FABRIC TO CHOOSE

FINISHES

BRUSHED BLACK ASHWOOD

CANALETTO WALNUT *

PLATINUM LACQUER

CLASSIC

Tub chair for dining tables and desks. The *Classic* range offers an extremely curved seat marked by a plain minimalism. The seat outer structure has a wide choice of wood finishing with matching metal base. Seat, armrests and backrest can be lined with all suitable Armani/Casa fabrics or Soft Touch Leathers in collection. Thin Leather is available only on the Canaletto Walnut structure. Covers are not removable. MADE IN ITALY.

DIMENSIONS
62x56x77h cm - Inch 24.2x22x30.3h
SH: 42 cm - Inch 16.5

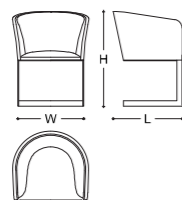

FINISHES

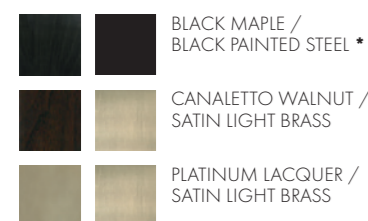

* CODE: 048010 ACEOP P0402, SOFT TOUCH LEATHER

JYLIA

Jylia is an elegant dining chair with rounded profiles, featuring a clear Eastern inspiration. The curved tapered seatback continues in the back legs. *Jylia* can either be upholstered in Sao Paulo fabric (colour Pale Gold/Platinum/Grey - ER065) or Siracusa fabric (colour Sage - ER049). MADE IN ITALY.

DIMENSIONS
58,5x55,5x88,5h cm - Inch 23x21.8x34.8h
SH: 48,5 cm - Inch 19.1

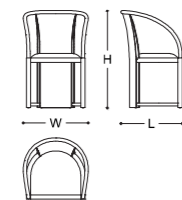

FINISHES



CODE: 048872 CH954 ER049, SIRACUSA FABRIC

RIMA with armrests

Dining chair with upholstered seat and seatback. The reverse of the seatback features a carved structure with a cut out geometric motif that leaves the upholstery visible from behind. *Rima* can be upholstered with all suitable Armani/Casa fabrics or Soft Touch Leathers in collection. MADE IN ITALY.

DIMENSIONS
53,5x57x93,5h cm - Inch 21x22.4x36.8h
SH: 49 cm - Inch 19.3

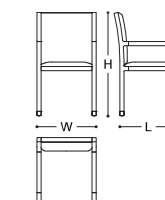

CODE: 045604 RMA0x, FABRIC TO CHOOSE

FINISHES



DUSTIN

Dustin is a director's chair originally designed for one of Giorgio Armani's yachts. It is available either fully upholstered in Thin Leather or Soft Touch Leather, or with a visible wooden frame. The Canaletto Walnut finish is combined with Thin Leather, while the Brushed Brown Oak version is matched with Soft Touch Leather. The version in Brushed Honey Ashwood can be combined with Cognac Thin Leather only. MADE IN ITALY.

DIMENSIONS
59x55x85h cm - Inch 23.2x21.7x33.5h
SH: 48 cm - Inch 18.9

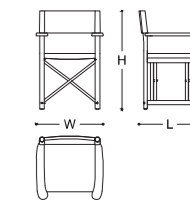

FINISHES

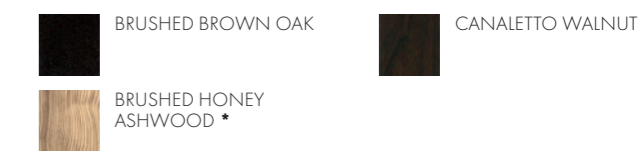

* CODE: 048132 CH994 C2554

ARIANNA

Dining chair marked by the rear legs continuing in the backrest. The structure is available in Black Brushed Ashwood or in Black Lacquer. Upholstery available in all suitable Armani/Casa fabrics; covers are removable.
MADE IN ITALY.

DIMENSIONS
47x55x94h cm - Inch 18.5x21.6x37h
SH: 48 cm - Inch 18.9

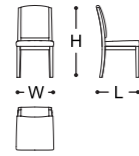

* CODE: 051212 LN00C ER200, ADDA FABRIC

OMAGE

Omage is a dining chair marked by a light silhouette, featuring a structure in solid wood. The structure of the seatback continues in the rear legs, creating a unique element. Since the wooden structure is very discrete and leaves the upholstery perfectly visible also from behind, Omage is a perfect match with very decorative fabrics. Upholstery available in all suitable fabrics, Thin and Soft Touch Leathers in collection. Covers are not removable.
MADE IN ITALY.

DIMENSIONS
45x55x89h cm - Inch 17.7x21.6x35h
SH: 48 cm - Inch 18.7

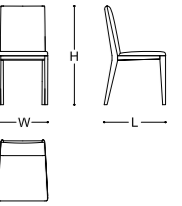

* CODE: 050101 NOC0x, FABRIC TO CHOOSE

FINISHES

-  BLACK LACQUER *
-  BRUSHED BLACK ASHWOOD **



** CODE: 051212 FRN0C ER183, AUSTRIA FABRIC

FINISHES

-  BLACK LACQUER
-  BLACK MAPLE
-  BRUSHED BLACK ASHWOOD
-  BRUSHED BROWN OAK
-  CANALETTO WALNUT *
-  PLATINUM LACQUER **



** CODE: 050101 LPL0x, FABRIC TO CHOOSE

GIOTTO

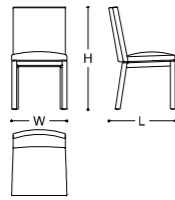

Giotto is a simple but very elegant chair. It features a 1 cm air between the seat and the rounded legs, for a lighter look. The padding is in polyurethane of different densities while the back is curved and slightly flexible, in order to be more comfortable and ensure the right ergonomics. The upholstery can be selected in all suitable Armani/Casa fabrics or Soft Touch Leathers in collection. It is also available in Thin Leather. Covers in fabric are completely removable. MADE IN ITALY.

DIMENSIONS
46x55x85h cm - Inch 18.1x21.7x33.5h
SH: 48 cm - Inch 18.9



* CODE: 048523 NOC0x, FABRIC TO CHOOSE

FINISHES

-  BRUSHED BROWN OAK
-  CANALETTO WALNUT *

OTTO

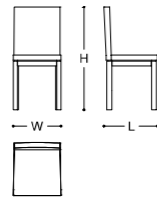

Otto is a chair with low backrest. The inner foam structure of the backrest allows a slight flexibility. Seat and backrest can be upholstered with all Soft Touch Leathers in collection or suitable Armani/Casa fabrics. MADE IN ITALY.

DIMENSIONS
45x49x90h cm - Inch 17.7x19.3x35.4h
SH: 48 cm - Inch 18.7



* CODE: 048670 NOC0x, FABRIC TO CHOOSE

FINISHES

-  CANALETTO WALNUT *
-  BRUSHED BROWN OAK

RIMA without armrests

Dining chair with upholstered seat and seatback, without armrests. The first version features the reverse of the seatback showing a distinctive carved structure with a cutout geometric motif that leaves the upholstery visible from behind. The second version, instead, features a reverse of the seatback with the outer frame only (with no geometric carving) that leaves the upholstery visible from behind. *Rima* can be upholstered with all suitable Armani/Casa fabrics or Soft Touch Leathers in collection. MADE IN ITALY.

DIMENSIONS
43,5x52x93,5h cm - Inch 17.1x20.5x36.8h
SH: 49 cm - Inch 19.3

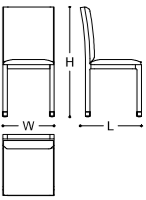

* CODE: 049335 LN00C TX126, PALERMO FABRIC

FINISHES

-  BLACK LACQUER *
-  BRUSHED BROWN OAK
-  BRUSHED BLACK ASHWOOD

DALIA

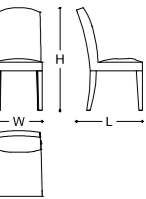

Dalia is a high comfort dining chair with flowing lines, which offers many customizable options. In the wooden legs option, the seat and the seatback can be upholstered with all Soft Touch Leathers or suitable Armani/Casa fabrics in collection. Thin Leather can be selected only in combination with Canaletto Walnut. The completely upholstered version, instead, features padded legs and Satin Natural Brass feet. In this case, the upholstery can be selected among all Soft Touch Leathers, suitable Armani/Casa fabrics or Technical Shagreen Fabric. A protective mini slip cover can be ordered separately. MADE IN ITALY.

DIMENSIONS
46,2x65,2x102h cm - Inch 18.2x24.6x40.2h
SH: 51 cm - Inch 20.1



* CODE: 048152 NOC0E TX019, NAGANO FABRIC

FINISHES

-  BLACK MAPLE
-  CANALETTO WALNUT *
-  BRUSHED BROWN OAK

SOFIA

Sofia is a dining chair marked by a rigorous geometry. The particularly tall backrest plays around full and empty spaces, given by the structure featuring slats with a squared section. The whole structure is either made of Shell Mosaic - with squared and rectangular mother-of-pearl tiles - or Transparent Methacrylate. An optional removable cushion for the seat - to be bought separately - can be selected in fabric. MADE IN ITALY.

DIMENSIONS

45x51x105h cm - Inch 17.7x20x41.3h

SH: 48 cm - Inch 18.9

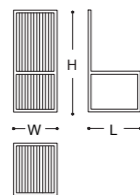

** CODE: 041484 CH468 C0000



* CODE: 041484 CH999 C3810

FINISHES



SHELL MOSAIC *



TRANSPARENT METHACRYLATE **

BAR

Tall stool with metal structure, perfect for breakfast corners in the kitchen or bar areas in the living room. Upholstery available in all suitable Armani/Casa fabrics or Soft Touch Leathers in collection. Available in two heights. MADE IN ITALY.

DIMENSIONS

LOW:

42x47x93h cm - Inch 16,5x18,5x36,6h

SH: 65 cm - Inch 25.6

TALL:

42x47x103h cm - Inch 16,5x18,5x40,5h

SH: 75 cm - Inch 29.5

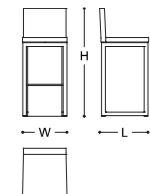

CODE: 045974 MNS0x, FABRIC TO CHOOSE

FINISHES



SATIN BLACK NICKEL

TROCADERO

Trocadero is the most iconic Armani/Casa table. Its silhouette is marked by the design of the four legs, placed so that they create the illusion of only two monolithic elements below the table top. Trocadero can be customized by choosing among four different sizes and many finishes, from classic to more particular ones. Options with two materials refer to the finishing of the top and of the legs respectively. MADE IN ITALY.

DIMENSIONS

210x105x75h cm - Inch 82.7x41.3x29.5h
 240x105x75h cm - Inch 94.5x41.3x29.5h
 270x110x75h cm - Inch 106.3x43.3x29.5h
 300x120x75h cm - Inch 118.1x47.2x29.5h

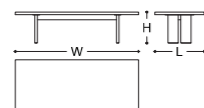

FINISHES

-  BLACK DRAFTED STUCCO / SATIN BLACK NICKEL
-  BRUSHED BROWN OAK
-  CANALETTO WALNUT
-  MUD DRAFTED STUCCO / SATIN BLACK NICKEL
-  PLATINUM WAVES LACQUER / TRANSPARENT METHACRYLATE *
-  WATOJI LACQUER / TATAMI LIQUID METAL **
-  WHITE GOLD DRAFTED STUCCO / SATIN BLACK NICKEL



* CODE: 048345 CH463 C1340 (270 CM)



** CODE: 045513 CH552 C2220 (240 CM)

PAGE

Page is a rectangular dining table, whose look catches the eye thanks to the particular base structure. In fact, legs are made of different wood laths (each with section of 3 x 5 cm) placed with a distance of 3 cm in between them: this feature creates an alternance of full and empty spaces, giving this important structure a lighter appearance. All laths of the same leg are connected at the base by a feet in Lacquer. Another important detail is the horizontal bar that connects the legs and runs below the top. The top has a thickness of 5 cm.

MADE IN ITALY.

DIMENSIONS

240x105x75h cm - Inch 94.5x41.3x29.5h

270x105x75h cm - Inch 106.3x41.3x29.5h

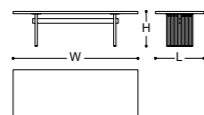

FINISHES



BRUSHED BLACK ASHWOOD



BRUSHED HONEY ASHWOOD /
CRISSCROSS NATURAL STRAW /
PLATINUM LACQUER *



* CODE: 050344 CH035 C0014 (270 CM)

NATHAN

Nathan is a dining table inspired by the Matrix collection of consoles, recalled by the extra thin tops (1 cm - Inch 0.4) and the metal legs with triangular section. The use of special finishes enriches the clean, elegant lines of the table, almost recalling the sartorial precision of a made-to-measure suit. The outer side of the legs is in the same finish of the top.
MADE IN ITALY.

DIMENSIONS

240x110x75h cm - Inch 94.4x43.3x29.5h

270x110x75h cm - Inch 106.2x43.3x29.5h

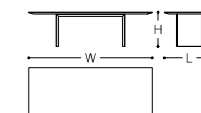

CODE: 045661 CA439 C0020 (270 CM)

FINISHES



BLACK CRACKLED LACQUER /
SATIN LIGHT BRASS

PLANET

The table *Planet* extends the range of round tables by Armani/Casa, inserting an option that features the X-shaped legs typical of our brand. The X shape immediately echoes other iconic ranges from our collection, like the *Oreste* small table and the *Club* cocktail cabinet. The structure - featuring legs and frame of the top in solid wood - is very light thanks not only to the slim legs, but also to a visual effect created by the top, that has a 4 cm thickness that reduces toward the edges. The *Planet* range also includes an accessory: the Lazy Susan, an optional rotating tray, to be bought separately, available in marble or glass. Alternatively, the version in Canaletto Walnut (Ø 180) features a built-in Lazy Susan in hand-polished Satin Light Brass. MADE IN ITALY.

DIMENSIONS

Ø 160x75h cm - Inch Ø 63x29.5h
 Ø 180x75h cm - Inch Ø 70.8x29.5h

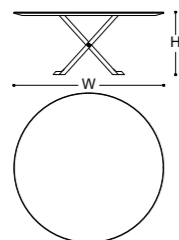

LAZY SUSAN:

Ø 80x3,5h cm - Inch Ø 31.4x1.3h
 Ø 100x3,5h cm - Inch Ø 39.3x1.3h

FINISHES

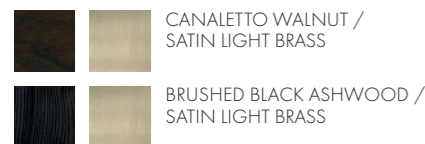

Lazy Susan



* CODE: 050363 CH550 C5656 (180 CM)



MELROSE

The *Melrose* range includes a round dining table and a set of two round coffee tables (to be bought separately). The top is surrounded by a thin frame in hand-polished Satin Light Brass, featuring a reduced thickness of only 2.2 cm to highlight the concept of lightness. The dining table is available exclusively with a top in Canaletto Walnut and legs in Satin Light Brass. The coffee tables, instead - available in two different sizes and various combinations of materials - can be placed close to each other and partially overlap.

MADE IN ITALY.

DIMENSIONS

DINING TABLE:

Ø 130x75h cm - Inch Ø 51.1x29.5h

COFFEE TABLES:

Ø 100x38h cm - Inch Ø 39.4x15h

Ø 68x35h cm - Inch Ø 26.8x13.8h

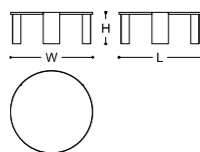

* CODE: 049327 CH107 C3555 (38H CM) / 049328 CH107 C3555 (35H CM)

FINISHES



** CODE: 049327 CH545 C0763 (38H CM) / 049328 CH545 C0763 (35H CM)

BOCCHERINI

Small round table with x-shaped legs and metal base.
MADE IN ITALY.

DIMENSIONS

Ø 64x61h cm - Inch Ø 25.2x24h

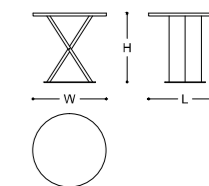

* CODE: 045943 CA918 C5653

FINISHES

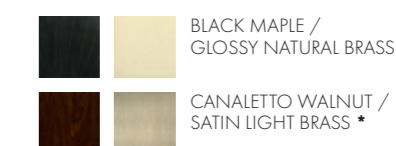

TED

Ted is a side table matching with the *Melrose* range of coffee tables. The design is marked by two thin legs (if seen from the side view) and a thin frame in Satin Light Brass. The top has a reduced thickness of only 2.2 cm, to highlight the concept of lightness. The colour and the texture of this intertwined material contrast with the purity of the Taj Mahal Quartzite of the top.

MADE IN ITALY.

DIMENSIONS

Ø 50x45h cm - Inch Ø 19.6x17.7h

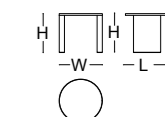

* CODE: 050783 CA417 C0461

FINISHES

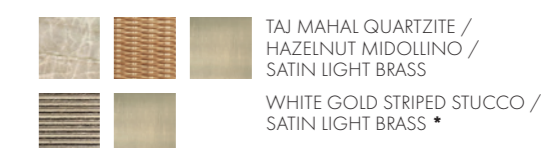

VALET

Coffee tables with pebble-shaped tops, recalling the lids of *Armani Privé* fragrances. The light finishing of the tops, in Brushed Silver Leaf, creates a beautiful contrast with the dark colour of the C-shaped legs, available in Canaletto Walnut or Black Maple: the latter enhances the contrast even more, since Black Maple presents a glossy surface. The three options have different heights, so that the tables can partially overlap when placed together. Valet can be purchased individually or in set of three. MADE IN ITALY.

DIMENSIONS

46x42x45h cm - Inch 18.1x16.5x17.7h

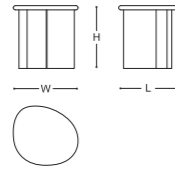

60x62x35h cm - Inch 23.6x24.4x13.8h

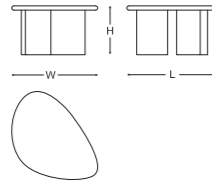

98x66x40h cm - Inch 38.6x26x15.7h

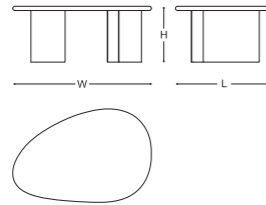

FINISHES

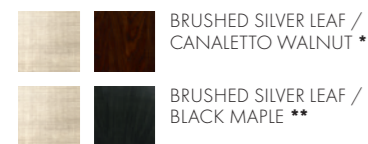

* CODE: 051061 CH461 C2041



** CODE: 051061 CH462 C0517

PLAY

Play is a range of versatile coffee/side tables. As their name suggests, they have been conceived to give you the maximum flexibility: in fact, each structure can be placed using the side you want as base, and it can be completed by adding the top. Bases and top are sold separately, in order to leave the maximum freedom of choice. A marking detail is the special technique used for the joints at the angles, which does not require any metal part. Table tops are available in leather (cuoio) with visible seams, or in Black Glass - a smoked tempered glass painted on the underside to create the illusion of a glossy black lacquer finish. MADE IN ITALY.

DIMENSIONS

100x100x40h cm - Inch 39.3x39.3x15.7h

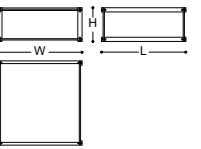

100x40x60h cm - Inch 39.3x15.7x23.6h

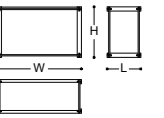

FINISHES



* CODE: 050369 CA918 C9553 (STRUCTURE), 050373 CA185 C0014 (TOP) / 050367 CA918 C9553 (STRUCTURE), 050370 CA185 C0014 (TOP)

GALASSIA

Galassia is a set of three squared small tables with different height, so that they can be placed under each other. The thickness of the top and legs is always 4 cm. Galassia small tables can be used in several ways, either placed singularly or together. This set comes in wood, leather or in a very precious finish made in Indonesia: Marine Pen shell, a combination of black and grey shell slices disposed to create a striped square on the top. MADE IN ITALY (Wood and leather versions). MADE IN INDONESIA (Shell version).

DIMENSIONS

50x50x50h cm – Inch 19.7x19.7x19.7h
 40x40x45h cm – Inch 15.7x15.7x17.7h
 30x30x40h cm – Inch 11.8x11.8x15.7h

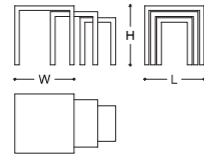

** CODE: 048534 CA907 C1654

FINISHES



* CODE: 048534 CA907 C1654

ORESTE

Oreste is a small table with crossed legs. It is available in different versions: the option in Brushed Brown Oak features a tray top that can be chosen squared or rectangular. The base and the tray have to be ordered separately. The chessboard Fair in the Armani/Casa accessories collection is designed to fit into the Oreste tray. Other options of the Oreste table feature, instead, regular tops (not tray) in precious finishes, available with squared top. MADE IN ITALY.

DIMENSIONS

RECTANGULAR:
 80x50x53h cm - Inch 31.5x19.7x20.9h

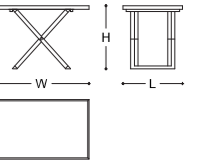

SQUARED:

60x60x53h cm - Inch 23.6x23.6x20.9h

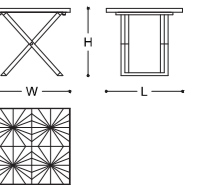

* CODE: 045229 CA336 C0053 (FOLDING BASE) / 045230 CA336 C0053 (TRAY)

FINISHES

With tray top

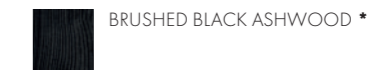

With flat top

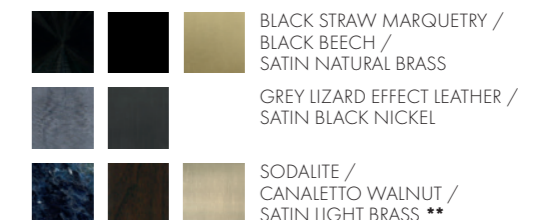

** CODE: 048077 CA967 C0034

LINK

Set of three small tables with rhomboidal shape. The structure features a base and a top element linked by four legs with the same section. The elements can be combined to create different geometric figures. Available in different versions, featuring wood, metal and leather with shagreen effect print. MADE IN ITALY.

DIMENSIONS
SINGLE ELEMENT:
 52x30x50h cm - Inch 20.5x11.8x19.7h
HEXAGONAL COMPOSITION:
 69x60x50h cm - Inch 27.1x23.6x19.7h

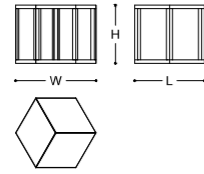

* CODE: 048941 CA772 C4856



** CODE: 048941 CA918 C4856

FINISHES



ESAGONO

Esagono is a small table/stool with an irregular hexagonal base. The versions in solid Canaletto Walnut and Caribbean Lacquer feature two curved holes that serve as handles, to make this piece easier to move. The version in fabric is available in different variants, each one paired with a matching decorative tassel. Fabric covers are removable. MADE IN ITALY.

DIMENSIONS
WOOD VERSIONS:
 35x35x39h cm - Inch 13.8x13.8x15.4h
FABRIC VERSIONS:
 35x35x40h cm - Inch 13.8x13.8x15.7h

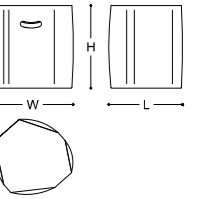

* CODE: 047788 CA779 C1340



** CODE: 047788 CA918 C4856



*** CODE: 047788 TE038 ER133, VERACRUZ FABRIC

FINISHES

Wood versions

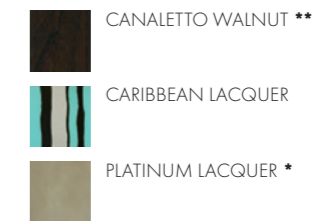

Fabric versions



NORIGAMI

Norigami takes inspiration from the idea of a folded sheet of paper transformed into a coffee table. Two identical elements placed closely create the illusion of two bridge tables crossing each other. *Norigami* is extra thin (2 cm only) and presents a linear design, contrasting with the exclusive finishes in which it is available. The Sky Lacquer version, hand-painted, draws inspiration from the work of the romantic English painter John Constable (1776 – 1837) and his Cloud Studies. Alternatively, *Norigami* is available in Greige Tulipier, or in a sophisticated bi-material combination of Greige Tulipier and Dove Grey Leather (cuoio).

MADE IN ITALY.

DIMENSIONS
SINGLE PIECE:
94x105x30h cm - Inch 37x41.3x11.8h

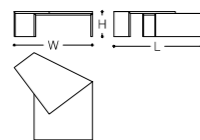

** CODE: 048961 CA332 C1432

FINISHES



* CODE: 048961 CH546 C0554

PURO

Puro - "pure" in Italian - is a range that really reflects its name: pure in the shape, pure in the materials. This side table reinterprets the sleek bridge shape typical of Armani/Casa: the timeless design is made precious by the contrast between Canaletto Walnut - Giorgio Armani's favourite wood - and the Kyoto Texture, a finish made with real linen fabric in natural colour featuring dark red lacquered inserts. Wood veneer is applied on the inner side and on the border of the top/sides. MADE IN ITALY.

DIMENSIONS
65x40x60h cm - Inch 25.6x15.7x23.6h

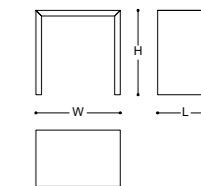

CODE: 050385 CH996 C1474

FINISHES



DANZICA

Minimal bridge-shaped coffee table, available in rectangular and squared versions. MADE IN ITALY.

DIMENSIONS
150x150x30h cm - Inch 59x59x11.8h*
130x130x30h cm - Inch 51.2x51.2x11.8h
130x65x30h cm - Inch 51.2x25.6x11.8h
160x90x30h cm - Inch 63x35.4x11.8h

*The version in Shell Mosaic is available in this dimension only.

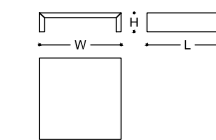

* CODE: 043967 CH466 C1842 (130X130 CM)

FINISHES



PARIS

Occasional table with bridge shape, marked by its thick veneered panels.
MADE IN ITALY.

DIMENSIONS
65x40x60h cm - Inch 25.6x15.7x23.6h

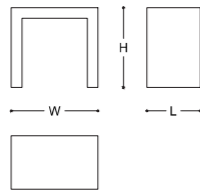

FINISHES



* CODE: 041148 CA867 C0020

TOMMY

Small G- and A-shaped tables in wood with different finishes.
MADE IN ITALY.

DIMENSIONS
40x40x42,5h cm - Inch 15.7x15.7x16.7h

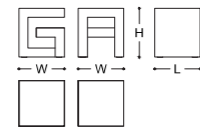

FINISHES

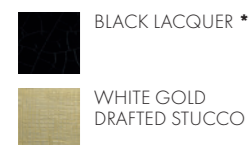

* CODE: 044351 CA862 C0020 (LETTER A) / 044352 CA862 C0020 (LETTER G)

ENYA

Enya is a console designed to fit perfectly in an entrance/corridor, a living room or behind sofas. The design is the same for all size options, with a slight difference for the longest versions: for technical reason, in fact, they feature an additional central leg that reaches the top, dividing the shelves in two.
MADE IN ITALY.

DIMENSIONS
150x44x75h cm - Inch 59.1x17.3x29.5h
205x44x75h cm - Inch 80.7x17.3x29.5h
285x44x75h cm - Inch 116.1x17.3x29.5h

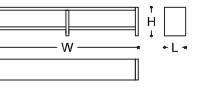

FINISHES

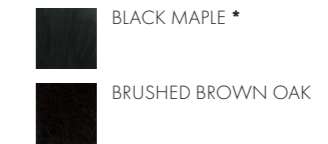

* CODE: 048333 CA867 C0020

SAN FRANCISCO

Set of low bridge consoles that can be used as coffee tables, made with very thick veneered panels.
MADE IN ITALY.

DIMENSIONS
100x44x44h cm - Inch 39.4x17.3x17.3h
150x44x44h cm - Inch 59.1x17.3x17.3h
200x44x44h cm - Inch 78.7x17.3x17.3h

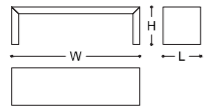

FINISHES

-  BLACK DRAFTED STUCCO *
-  MUD DRAFTED STUCCO
-  WHITE GOLD DRAFTED STUCCO



* CODE: 041163 CA862 C0020 (200 CM)

SEINE

Bridge-shaped consoles, made with thick veneered panels. Available in many different finishes, from classic to more particular ones..
MADE IN ITALY.

DIMENSIONS
125x44x70,5h cm - Inch 49.2x17.3x27.8h
148x50x94h cm - Inch 58.3x19.7x37h
180x50x110h cm - Inch 70.9x19.7x43.3h

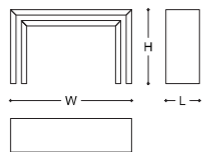

FINISHES

-  BLACK DRAFTED STUCCO *
-  BLACK MAPLE
-  BRUSHED BROWN OAK
-  MUD DRAFTED STUCCO
-  WHITE GOLD DRAFTED STUCCO



* CODE: 040397 CA862 C0020 (110H CM) / 040393 CA862 C0020 (94H CM)

EVANS

The Evans console features a hidden storage compartment closed by a flap door. Available in one size only, this console is made of a suspended central element and two built-in flush legs in metal with square section placed on the sides. The hidden compartment has no exposed hinges to be almost invisible, and features a slow closing system.
MADE IN ITALY.

DIMENSIONS
120x36x80h cm - Inch 47.2x14.2x31.5h

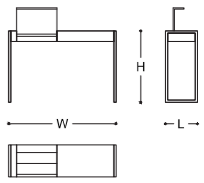

* CODE: 048308 CA825 C0056

FINISHES

-  BRONZE STRAW MARQUETRY / GLOSSY NATURAL BRASS *
-  TECHNICAL SHAGREEN FABRIC / SATIN NATURAL BRASS

MATRIX

Four consoles to mix together or display separately. The medium size is perfect also as a coffee table, while the two smaller ones can be used as side/occasional tables. Base structure in metal with triangular section, which creates a particular effect thanks to the reflection of light. Extra thin top of only 1 cm. The *Matrix* range shares the same base structure as the *Nathan* dining table, the *Mirò* buffet and the *Smart* range. MADE IN ITALY.

DIMENSIONS
160x40x75h cm - Inch 63x15.7x29h

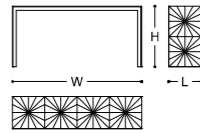

140x60x40h cm - Inch 55x23.6x15.7h

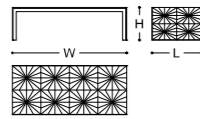

FINISHES

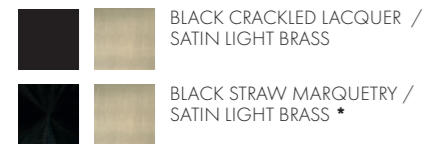

* CODE: 049331 CA885 C0020 (160 CM) / 049330 CA885 C0020 (140 CM)

SMART

Smart is a range of pieces matching the already existing *Matrix - Mirò - Nathan* ranges. All these products share the same concept: a bridge-shaped base structure in metal featuring a triangular section, which creates a particular effect thanks to the reflection of light. All *Smart* pieces are equipped with container units in wood, hosting a different number of drawers. MADE IN ITALY.

DIMENSIONS
SMART TALL:
170x45x75h cm - Inch 66.9x17.7x29.5h

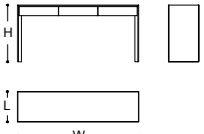

SMART LOW:
140x60x40h cm - Inch 55.1x23.6x15.7h

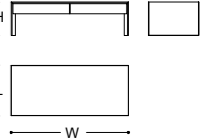

CODE: 050739 CA918 C4856



CODE: 050740 CA918 C4856

FINISHES



ORIZZONTE

The *Orizzonte* console stands out for its neat design, marked by the reduced thickness of the top and the legs. The tubular structure embraces the top in a very elegant way.
MADE IN ITALY.

DIMENSIONS
140x40x80h cm - Inch 55.1x15.7x31.4h

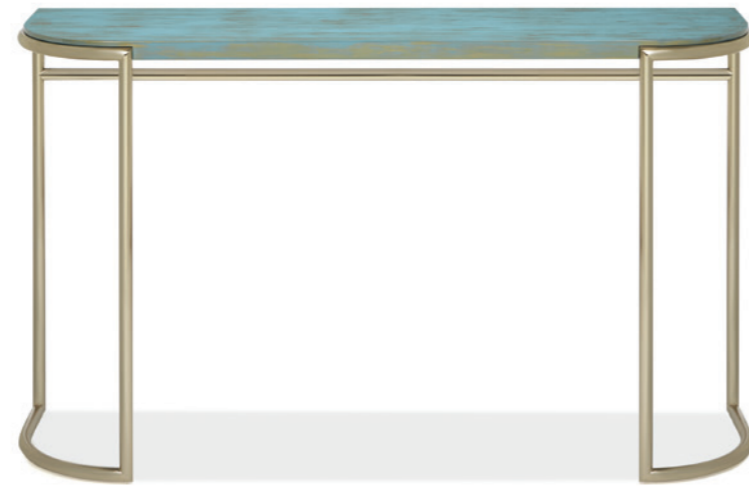
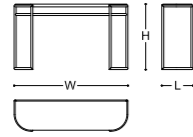

* CODE: 050108 CA569 C1084



** CODE: 050108 CA918 C5653

FINISHES

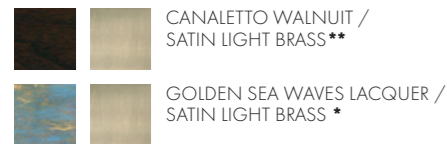

VENUS

Console with sinuous design, marked by curved lines defining an almost sculptural look. The most particular feature of *Venus* is the base, created by a continuous ribbon element in Platinum Lacquer. A final touch of preciousness is given by the stunning Orsini Glass used for the oval top.
MADE IN ITALY.

DIMENSIONS
170x50x80h cm - Inch 66.9x19.7x31.5h

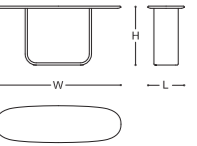

CODE: 051063 CH460 C0099

FINISHES



VEGA

Console with central drawer designed for the Armani Residences in Madison Avenue, New York, by the Armani/Casa's *Interior Design Studio*. The structure features two C-shaped legs in Satin Light Brass, whose outer side - as well as the main body of the piece - is entirely clad in Shell Mosaic. The reduced thickness of all elements confers a sleek timeless look to the whole piece. Metal profile and details in Satin Light Brass.
MADE IN ITALY.

DIMENSIONS
141x46x80h cm - Inch 55.5x18.1x31.5h

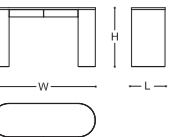

CODE: 051062 CH999 C3810

FINISHES



DAVID

The David range of chests of drawers includes also a bedside table, available in two different sizes.
MADE IN ITALY.

DIMENSIONS
52x42,5x44,5h cm - Inch 20.5x16.8x17.6h
72x42,5x44,5h cm - Inch 28.4x16.8x17.6h

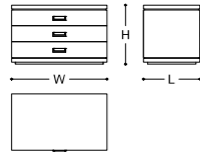

FINISHES
CANALETTO WALNUT / SATIN LIGHT BRASS



CODE: 048172 CA918 C5653 (52 CM)

MENEO

Meneo is a bedside table conceived to match with the Morfeo bed. It features rounded edges and a single extractable shelf moving on a flat slide, refined with a back bar to prevent objects from falling.
MADE IN ITALY.

DIMENSIONS
60x45x45h cm - Inch 23.6x17.7x17.7h

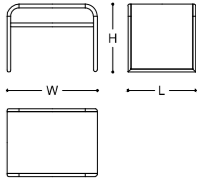

* CODE: 049324 CH557 C6953

FINISHES
CANALETTO WALNUT
CANALETTO WALNUT / TECHNICAL CHINCHILLA FABRIC *

DAMASIO

Bedside table with x-shaped legs that support a square storage unit with rounded corners and one drawer. The oak version features legs in solid wood, while the others have legs and top profiles in metal.
MADE IN ITALY.

DIMENSIONS
55x55x45h cm - Inch 21.7x21.7x17.7h

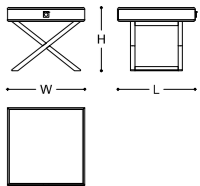

* CODE: 048159 CA885 C0020

FINISHES
BLACK STRAW MARQUETRY / SATIN NATURAL BRASS *
BRUSHED BROWN OAK
CANALETTO WALNUT / SATIN LIGHT BRASS

CIMAROSA

Round bedside table with x-shaped legs featuring a drawer built into the top frame. The guide rails of the drawers are in wood, to save room inside the drawer. Metal base. MADE IN ITALY.

DIMENSIONS
 Ø 50x50,5h cm - Inch Ø 19.7x19.9h

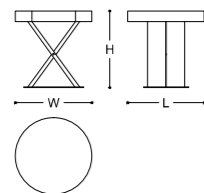

FINISHES

-   BLACK MAPLE / GLOSSY NATURAL BRASS
-   CANALETTO WALNUT / SATIN LIGHT BRASS
-   METAL LACQUER / SATIN BLACK NICKEL
-   WHITE GOLD LEAF / SATIN NATURAL BRASS *



* CODE: 048092 CA835 C0461

GIÒ

This bedside table recalls the classic Armani/Casa bridge shape, introducing a circular section. Available in two finishes, the version in Brushed Brown Oak features a top upholstered in Tucson technical fabric. MADE IN ITALY.

DIMENSIONS
 Ø 50x50h cm - Inch Ø 19.7x19.7h

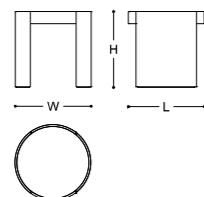

FINISHES

-   BRUSHED BROWN OAK / TUCSON FABRIC (ER130 - PLATINUM)
-  GREIGE TULIPIER *



* CODE: 048535 CH466 C1842

RUSSEL

The Russel range shows a circular top. The tubular structure - covered with thick leather (cuoio) and enriched by metal details - surrounds the top and continues in the legs and the base. The bedside table has one frontal drawer. MADE IN ITALY.

DIMENSIONS WITH DRAWER
 Ø 55x50h cm - Inch Ø 21.65x19.7h

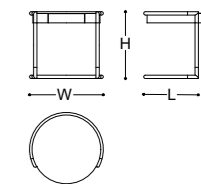

WITHOUT DRAWER
 Ø 55x50h cm - Inch Ø 21.65x19.7h

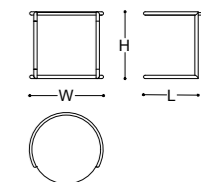

* CODE: 050605 CA900 00151



* CODE: 050630 CA900 00151

FINISHES

-    CANALETTO WALNUT / COGNAC LEATHER (CUOIO) / SATIN LIGHT BRASS *
-    CANALETTO WALNUT / DOVE GREY LEATHER (CUOIO) / SATIN LIGHT BRASS

AMEDEO

Amedeo was born from the union of two shapes part of the Armani/Casa collection. The bed itself takes inspiration from the Ryoko range, an entirely upholstered bed with invisible feet that, together with the slightly tilted sides of the bedframe, make the structure look suspended (feet and bedframe are 10 cm and 15 cm high respectively). The headboard, instead, is particularly wide to embrace bedside tables and comes from the back structure of the *Virgola* bookcase; the frame is in solid Greige Tulipier, while the back of this structure is in Greige Tulipier veneer. Available in all fabrics in collection; fabric covers are removable. The bed is available in five different mattress sizes.
MADE IN ITALY.

DIMENSIONS

MAT. 160 cm - Inch 63
162x202x25h cm - Inch 63.7x79.5x9.8h

MAT. 170 cm - Inch 66.9
172x202x25h cm - Inch 67.7x79.5x9.8h

MAT. 180 cm - Inch 70.8
182x202x25h cm - Inch 71.6x79.5x9.8h

QUEEN USA
155x205x25h cm - Inch 61x80.7x9.8h

KING USA
195x205x25h cm - Inch 76.7x80.7x9.8h

SH: 55 cm - Inch 21.7

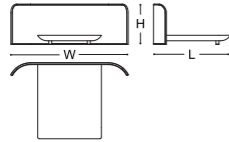

HEADBOARD:

320x35x110h cm - Inch 126x13.7x43.4h
340x35x110h cm - Inch 133.8x13.7x43.4h



CODE: 051993 CT00C ER200 / 051996 CT00C ER200 (MAT. 170 CM), ADDA FABRIC

FINISHES

 GREIGE TULIPIER

DANDY

Bed with completely padded high headboard. The headboard is designed in the shape of an arch rounded in the floor plan view, so that the most external parts are detached from the wall: this feature endows the bedroom interior with lightness and motion and allows the bed to be located centrally in a room. The header comes in two different sizes and must be ordered separately. The sommier is available with or without container. *Dandy* can be upholstered with all suitable Armani/Casa fabrics (removable) or Soft Touch Leathers in collection.
MADE IN ITALY.

DIMENSIONS

BED WITH AND WITHOUT CONTAINER:

MAT. 160 cm - Inch 63
168x204x30h cm - Inch 66.1x80.3x11.8h

MAT. 170 cm - Inch 66.9
178x204x30h cm - Inch 70x80x11.8h

MAT. 180 cm - Inch 70.8
188x204x30h cm - Inch 74x80x11.8h

QUEEN USA
160x207x30h cm - Inch 63x81.5x11.8h

KING USA
201x207x30h cm - Inch 79.1x81.5x11.8h

SH: 55 cm - Inch 21.7

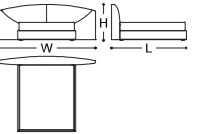

HEADBOARD:

260x26x110h cm - Inch 102.4x10.2x43.4h
300x26x110h cm - Inch 118.2x10.2x43.4h



CODE: 048135 CT00x, FABRIC TO CHOOSE / 048142 CT00x (MAT. 170 CM), FABRIC TO CHOOSE

ORIS

Oris is a bed featuring rectangular padded headboard, which is considerably larger than the bedframe. Upholstery available in all suitable fabrics or Soft Touch Leathers in collection; covers are not removable.

MADE IN ITALY.

DIMENSIONS

MAT. 160 cm - Inch 63
162x201x25h cm - Inch 63.7x79.1x9.8h

MAT. 170 cm - Inch 66.9
172x201x25h cm - Inch 67.7x79.1x9.8h

MAT. 180 cm - Inch 70.8
182x201x25h cm - Inch 71.6x79.1x9.8h

QUEEN SIZE USA
154x205x25h cm - Inch 60.6x80.7x9.8h

KING SIZE USA
195x205x25h cm - Inch 76.6x80.7x9.8h

SH: 55 cm - Inch 21.7

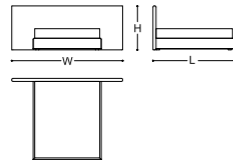

The headboard is available in three sizes, for which a fixed matching has been selected:

- Smaller headboard (280x115h cm - Inch 110.2x45.2) for the 160 cm - Inch 63 and Queen size mattress;
- Medium headboard (290x115h cm - Inch 114.1x45.2) for the 170 cm - Inch 66.9 mattress;
- Larger headboard (313x115h cm - Inch 123.2x45.2) for the 180 cm - Inch 70.8 and King size mattress.

RYOKO

Entirely upholstered bed with invisible feet that, together with the slightly tilted sides of the bedframe, make the bed look suspended (feet and bedframe are 10 cm and 15 cm high respectively). All edges present an anthracite piping. Available in all fabrics and Soft Touch Leathers in collection; fabric covers are removable. The bed is available in five different mattress sizes.

MADE IN ITALY.

DIMENSIONS

MAT. 160 cm
162x221x90h cm - Inch 63.7x87x35.4h

MAT. 170 cm
172x221x90h cm - Inch 67.7x87x35.4h

MAT. 180 cm
182x221x90h cm - Inch 71.6x87x35.4h

QUEEN SIZE USA
154x224x90h cm - Inch 60.6x88.1x35.4h

KING SIZE USA
195x224x90h cm - Inch 76.7x88.1x35.4h

SH: 55 cm - Inch 21.7

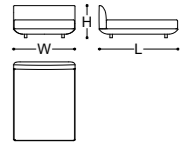

CODE: 050149 CT00x / 050152 CT00x (MAT. 170 CM), FABRIC TO CHOOSE



CODE: 050593 CT00C ER094 (MAT. 170 CM), TALLINN FABRIC

ROMA

Roma is a bed with upholstered headboard and orthopaedic base with wooden slats. It is available with low or tall headboard. Roma can be upholstered with all Soft Touch Leathers (not removable) or suitable Armani/Casa fabrics (removable) in collection. Wooden feet. MADE IN ITALY.

DIMENSIONS

LOW HEADER VERSION

MAT. 160 cm - Inch 63
164x218x80h cm - Inch 64.5x85.8x31,5h

MAT. 170 cm - Inch 66.9
174x218x80h cm - Inch 68.5x85.8x31,5h

MAT. 180 cm - Inch 70.8
184x218x80h cm - Inch 72.4x85.8x31,5h

KING USA
198x222x80h cm - Inch 78x87.4x31,5h

QUEEN USA
157x222x80h cm - Inch 61.8x87.4x31,5h

SH: 47 cm - Inch 18.5

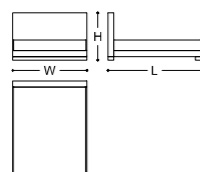

TALL HEADER VERSION

MAT. 160 cm - Inch 63
164x218x110h cm - Inch 64.5x85.8x43.3h

MAT. 170 cm - Inch 66.9
174x218x110h cm - Inch 68.5x85.8x43.3h

MAT. 180 cm - Inch 70.8
184x218x110h cm - Inch 72.4x85.8x43.3h

KING USA
198x222x110h cm - Inch 78x87.4x43.3h

QUEEN USA
157x222x110h cm - Inch 61.8x87.4x43.3h

SH: 47 cm - Inch 18.5

FINISHES

BRUSHED BROWN OAK *

CANALETTO WALNUT



* CODE: 048684 RMA0x (MAT. 170 CM), FABRIC TO CHOOSE

ROLAND

Roland is a bed with a tubular hard structure. The tubular elements are covered with thick leather (cuoio) and enriched by metal details with rounded corners on the joints. The tilted header is created by two different cushions, which can be upholstered with all fabrics and Soft Touch Leathers in collection; fabric covers are removable. The bed is available in five different mattress sizes. MADE IN ITALY.

DIMENSIONS

MAT. 160 cm - Inch 63
162x228x90h cm - Inch 63.7x89.7x35.4h

MAT. 170 cm - Inch 66.9
172x228x90h cm - Inch 67.7x89.7x35.4h

MAT. 180 cm - Inch 70.8
182x228x90h cm - Inch 71.6x89.7x35.4h

QUEEN SIZE USA
154x233x90h cm - Inch 60.6x91.7x35.4h

KING SIZE USA
195x233x90h cm - Inch 76.7x91.7x35.4h

SH: 55 cm - Inch 21.7

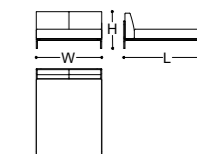

FINISHES

COGNAC LEATHER (CUOIO) / SATIN LIGHT BRASS *

CORTECCIA LEATHER (CUOIO) / SATIN LIGHT BRASS

DOVE GREY LEATHER (CUOIO) / SATIN LIGHT BRASS



* CODE: 050661 CT00x (MAT. 170 CM), FABRIC TO CHOOSE

MORFEO

Morfeo comes from the idea of a floating bed, a concept that becomes reality thanks to the thin, softly curved headboard and footboard. The structure is made of a single metal element, curved at the ends, clad in different fabrics according to the version and outlined with a rounded solid wood frame. All covers are not removable. The *Morfeo* bed matches with the *Meneo* bedside tables and shares the same concept of the *Onda* chaise-longue and the *Sharon* range. MADE IN ITALY.

DIMENSIONS

Mat. 160 cm - Inch 63
 166x236x93h cm - Inch 65.3x93x36.6h

Mat. 170 cm - Inch 66.9
 176x236x93h cm - Inch 69.3x93x36.6h

Mat. 180 cm - Inch 70.8
 186x236x93h cm - Inch 73.2x93x36.6h

King Usa
 199x239x93h cm - Inch 78.3x94x36.6h

Queen Usa
 158x239x93h cm - Inch 62.2x94x36.6h

SH: 50 cm - Inch 19.7

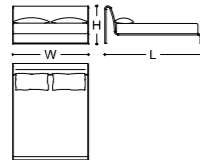

FINISHES

-  CANALETTO WALNUT / SUVA FABRIC (ALL COLOURS) **
-  CANALETTO WALNUT / TECHNICAL CHINCHILLA FABRIC
-  CANALETTO WALNUT / VIENNA FABRIC *



* CODE: 045988 TS147 ER160 (MAT. 170 CM)



* CODE: 045988 NOC0E TX176 (MAT. 170 CM)

SLAT STRUCTURES

All Armani/Casa beds include a double bed slat structure with a steel frame. The frame can be structural (so the whole slat structure cannot be separated from the bed) or removable (the whole slat structure can be separated from the bed).

All types comprise a system with flexible slats in beech wood. Depending on the range, each bed features a different variant of this system:

- Basic slats: flexible slats with no additional options;
- Shock-absorbing slats: each slat lies on a flexible rubber support, which adapts the slat itself depending on the weight above;
- Adjustable slats: double slats kept together by a couple of adjustable plastic rings. The farther the rings on the same slat are, the more the slat becomes rigid.

	BASIC SLATS	SHOCK-ABSORBING SLATS	ADJUSTABLE SLATS
STRUCTURAL FRAME (STEEL)	ROLAND		AMEDEO MORFEO RYOKO
REMOVABLE FRAME (STEEL)	ROMA	DANDY ORIS	

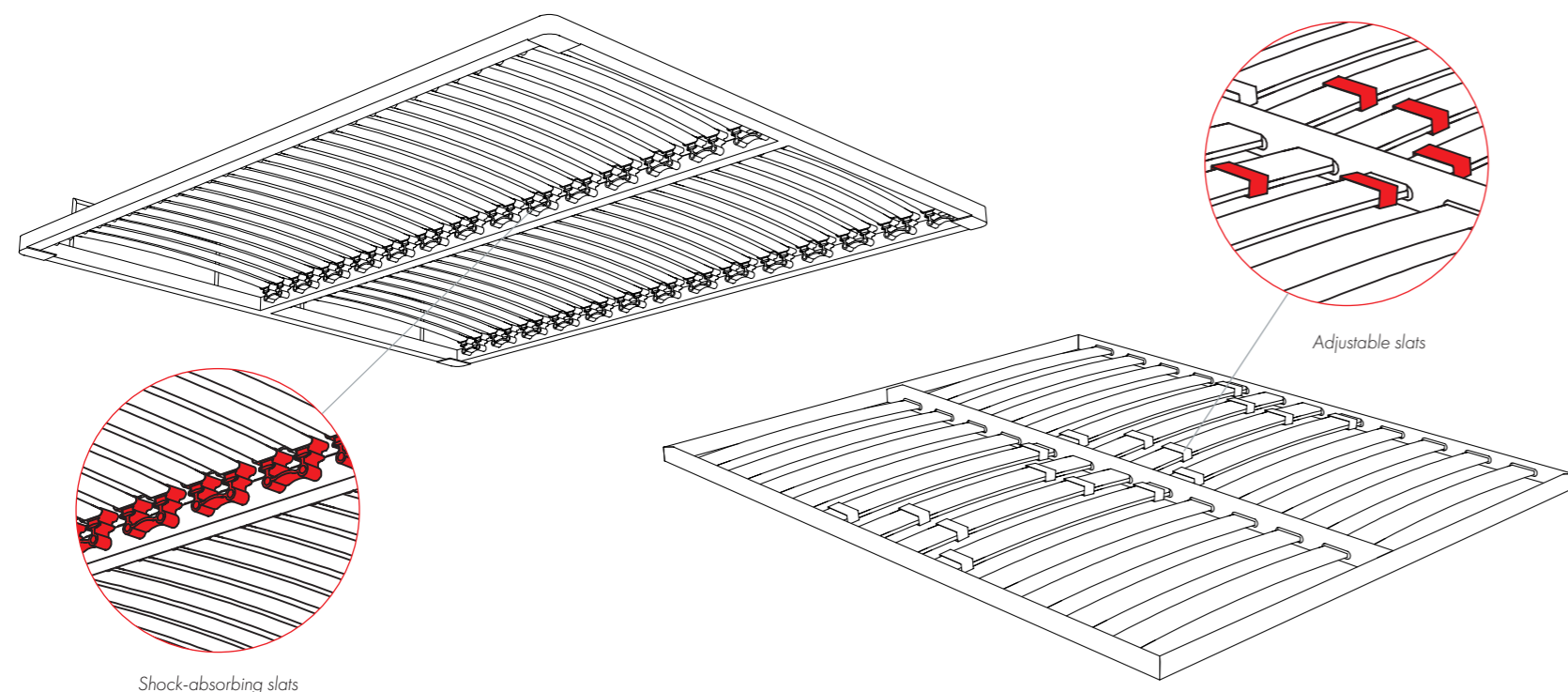

GARCIA

Classic hypoallergenic mattress in latex of superior quality, h. 25 cm.

Springs: Independent spring system Supermicro 3000 h. 140 mm, 7 different comfort zones, spring section of 0.9/1.0 mm.

Density: 1100 springs/m².

Frame: Perimeter box in high-density expanded polyurethane.

Layers: Upper and lower layer in Latex with passing-through holes h. 40 mm.

Upholstery: Removable outer cover with perimeter borders and zips on both sides.

Padding: Anallergic wadding 300 gr/m².

Fabric: Jacquard fabric with Armani/Casa logo.

GARLAND

High-quality mattress with double thickness: the main body with springs and a thinner additional mattress on top filled with natural feathers. h. 27 cm.

BASE MATTRESS

Springs: Independent spring system Micropocket h. 140 mm with 7 different comfort zones, spring section of 1.1/1.2 mm.

Density: 600 springs/m².

Frame: Perimeter box in high-density expanded polyurethane.

Layers: Upper and lower layer in pyramid polyurethane foam Firm Support h. 30 mm.

Upholstery: Non-removable outer cover with perimeter borders.

Padding: Anallergic wadding 300 gr/m².

Fabric: Jacquard fabric with Armani/Casa logo.

TOP PILLOW

Upholstery: Removable outer cover with perimeter borders.

Padding: Anallergic wadding 300 gr/m².

Fabric: Jacquard fabric with Armani/Casa logo.

Inner thin mattress padded with goose feathers, tied to the main mattress thanks to leatherette straps FastStrap® system (trademark).



CAMILLA

Writing desk with Art Déco inspiration. The rigorous lines of *Camilla* mix Satin Light Brass with Canaletto Walnut to achieve a look marked by a timeless elegance.
MADE IN ITALY.

DIMENSIONS
133x66,5x75h cm - Inch 54.4x26.2x29.5h

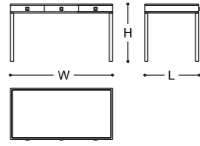

CODE: 048048 CA918 C5653

FINISHES



EUCLIDE

Euclide has a light look, thanks to its thin top and chests of drawers supported by only two metal ribbon legs. *Euclide* is designed to be used from both sides, since it has four drawers with traditional guide rails on each side. This desk is equally suitable for being used in a study or in a bedroom. The frames of the drawers are in solid wood.
MADE IN ITALY.

DIMENSIONS
150x70x75h cm - Inch 59.1x27.6x29.5h

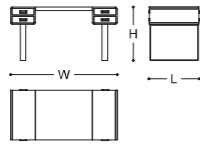

CODE: 048276 CA867 C0020

FINISHES



ROUSSEAU

This elegant sleek desk presents the same features of the *Olimpia* bookcase and the *Prestige* sideboard: tubular elements clad in thick leather (cuoio) are connected by metal ribbons in brass, becoming decorative and functional details at the same time. *Rousseau* enhances the concept of lightness thanks to its thin top (frontal edge of 27 mm) and the legs completed by metal feet. The desk is equipped with four drawers. A particularly rich version features top and sides in hand-polished brass; on this version, top and sides are made out of a single metal piece. A desk pad in thick leather (cuoio) with embossed logo can be bought separately and was conceived to increase comfort while working on the desk.
MADE IN ITALY.

DIMENSIONS
150x65x75h cm - Inch 59x25.5x29.5h

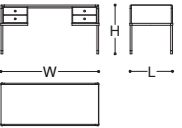

* CODE: 050602 CA900 00151

FINISHES

Wood versions



Metal version



** CODE: 050602 CA426 C0052

JOLIE

Featuring minimal lines with hints of the Thirties, *Jolie* is a two-drawer desk with wooden structure and leather top. It is equipped on each side with pockets conceived to store paper and magazines. Underneath the worktop two drawers open with the aid of a small leather handle with metal GA logo detail. The drawers feature wooden guide rails, which allow more height to the inside of the drawer. The drawer fronts show refined visible stitching. *Jolie* has no back panel, but the solid wood structure is conceived to ensure optimal stability. MADE IN ITALY.

DIMENSIONS
140x70x75h cm - Inch 55.1x27.5x29.5h

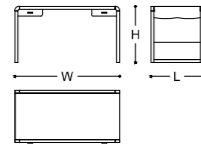

CODE: 048873 CA900 C4858

FINISHES



CANALETTO WALNUT /
LEATHER (CUOIO) TO CHOOSE

OLIVIA

Olivia is a desk reinterpreting the iconic bridge shape through a slightly curved top: its reduced dimensions make it suitable also to be used as a vanity table. *Olivia* features a hole for cables and a single central drawer. The minimalist design is enriched with a top in Shell Mosaic and legs in Platinum Lacquer, whose outer sides are carved to create an undulated surface. MADE IN ITALY.

DIMENSIONS
136x66x75h cm - Inch 53.5x25.9x29.5h

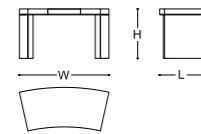

CODE: 050102 CH999 C2254

FINISHES



SHELL MOSAIC /
PLATINUM LACQUER

STENDHAL

The *Stendhal* secretary desk, marked by a strong *Art Déco* inspiration, is clad in the Jade Shagreen Textured Leather: the texture is reproduced through a printing process followed by a hand-brushing which lightens the colour in relief. Inner structure in Canaletto Walnut, with handles, feet and cable hole in Satin Light Brass. An important technical feature is the opening system of the folding top: through a special clutch device with an exposed steel wire, the top opens slowly without dropping and keeps its stability when working on it. *Stendhal* features an inner LED lighting system, with a switch button located under the shelf. MADE IN ITALY.

DIMENSIONS
120x51x123h cm - Inch 47.2x20.1x48.4h

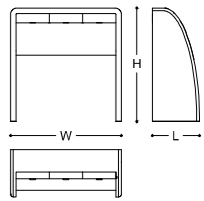

CODE: 050768 CH995 C0086

FINISHES



CANALETTO WALNUT /
JADE SHAGREEN TEXTURED LEATHER /
SATIN LIGHT BRASS

PLAY

The *Play* collection includes a bookcase designed to complement the range of side/coffee tables. Its perfectly bifacial design makes it ideal as a divider, seamlessly integrating into open spaces. The structure is either made of solid Brushed Black Ashwood or solid Canaletto Walnut - matching the finishes of the tables - while the shelves present an inner structure in aluminium clad in leather (cuoio) with visible seams. **MADE IN ITALY.**

DIMENSIONS
180x40x172h cm - Inch 70.8x15.7x67.7h

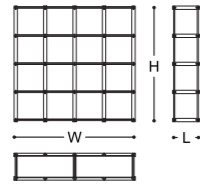

FINISHES

LEATHER (CUOIO) TO CHOOSE /
BRUSHED BLACK ASHWOOD

LEATHER (CUOIO) TO CHOOSE /
CANALETTO WALNUT *



* CODE: 051221 CA918 C9553 (STRUCTURE) / 051223 CA185 C0014 (SHELF)

OLIMPIA

The free-standing *Olimpia* bookcase is made of a rectangular wooden frame hosting three shelves. This structure is sustained - and lifted from the ground - by five vertical tubular bars covered with leather, whose asymmetrical disposition gives movement to the entire piece. Stripes of metal, similar to ribbons, have the double function of carrying the shelves and giving more stability to the entire bookcase. **MADE IN ITALY.**

DIMENSIONS
200x40x175h cm - Inch 78.7x15.7x68.8h

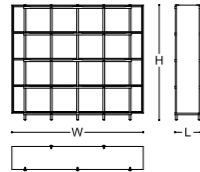

FINISHES

BRUSHED BLACK ASHWOOD /
DOVE GREY LEATHER (CUOIO) /
SATIN LIGHT BRASS

CANALETTO WALNUT /
DOVE GREY LEATHER (CUOIO) /
SATIN LIGHT BRASS *



* CODE: 050119 CA941 C4856

VIRGOLA

The shape of the *Virgola* free-standing bookcase is inspired by a parenthesis: the curved structure in Patinated Silver Leaf or Platinum Lacquer creates a beautiful background for the metal uprights in Satin Light Brass, while shelves are made with the breath-taking Orsini Glass. **MADE IN ITALY.**

DIMENSIONS
204x38x172h cm - Inch 80.3x14.9x67.7h

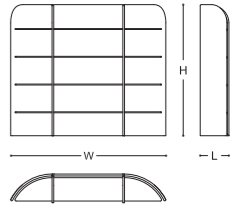

* CODE: 051064 CH459 C3941

FINISHES

PLATINUM LACQUER /
ORSINI GLASS /
SATIN LIGHT BRASS *

PATINATED SILVER LEAF /
ORSINI GLASS /
SATIN LIGHT BRASS

RIESLING

Bar cabinet marked by a large storing unit that lies on a thin linear structure. *Riesling* is available in different precious finishes that enrich the neat design. The back of the doors is equipped with short shelves conceived to store glassware. The version in Moonlight Decoration features a tubular structure in metal, while others have legs with squared section. The version in Hazelnut Midollino presents handles in bioresin and interiors covered in Cognac Thin Leather. **MADE IN ITALY.**

DIMENSIONS
76x57x154h cm - Inch 30x22.4x60,6h

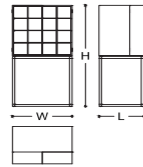

FINISHES

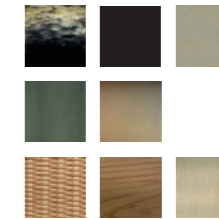

MOONLIGHT DECORATION /
BLACK LACQUER /
TECHNICAL PEARL GOLD FABRIC *
TECHNICAL SHAGREEN FABRIC /
SMOKED GOLD **
HAZELNUT MIDOLLINO / OLIVE /
SATIN LIGHT BRASS /
COGNAC THIN LEATHER ***



FINISHES
GOLDEN CANNETÉ METHACRYLATE /
SATIN LIGHT BRASS



CODE: 048069 CH467 C0161

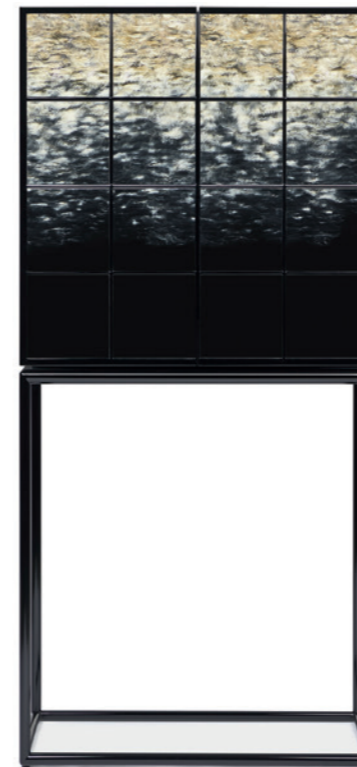

* CODE: 048069 CA668 C0020

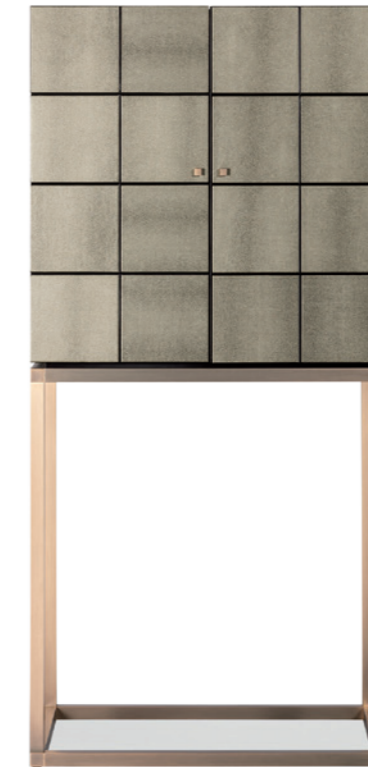

** CODE: 048069 CA956 C0041



*** CODE: 048069 CH225 C3555

CLUB

One of the most iconic cocktail cabinet by Armani/Casa, *Club* takes inspiration from vintage travel furniture thanks to its x-shaped legs. This cocktail cabinet features container doors for the storage of glasses. The outer shell is marked by Lacquered Red Linen: a finish featuring real linen fabric coupled with gold leaf and then painted in red, where a layer of transparent lacquer adds the final shiny touch leaving the textured surface visible. Inside, the beautiful Singapore fabric - marked by the design of Japanese-inspired fans - creates an unexpected contrast with the outside. The interior - illuminated by a LED system - holds a lower pull-out shelf covered by an extralight transparent tempered glass (5 mm thick) and a foldout top. A single lower unit, opened thanks to a push-pull system, hosts a small drawer conceived to store cocktail utensils. MADE IN ITALY.

DIMENSIONS
79x61x130h cm - Inch 31.1x24x51.2h

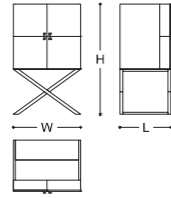

* CODE: 048075 CH998 C0074

FINISHES



CIRCLE

Circle is a range of revolving tables, conceived to store barware, available in two sizes. The large version features two curved doors and two pull-out drawers. The inside of the doors is equipped with a structure to hold stem glasses, while the drawers can be used to store bottles. The small but taller version opens with the aid of a slim metal handle, and the inside of the curved doors is equipped with two shelves. *Circle* takes its inspiration from the travel furniture typical of the 20s and the 30s, object-sculptures that were transformable and suggesting several functions. The cabinet, thanks to a fixed turning base, can rotate of 360°. MADE IN ITALY.

DIMENSIONS
SMALL:
Ø 50x65h cm - Inch Ø 19.7x25.6h

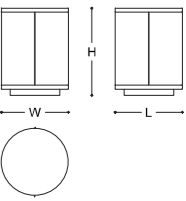

LARGE:
Ø 81x53h cm - Inch Ø 31.9x20h

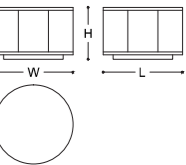

** CODE: 048067 CA863 C0461



* CODE: 048066 CA862 C0020

FINISHES



SMART

Smart is a range of pieces matching the already existing Matrix - Mirò - Nathan ranges. All these products share the same concept: a bridge-shaped base structure in metal featuring a triangular section, which creates a particular effect thanks to the reflection of light. All Smart pieces are equipped with container units in wood, hosting a different number of drawers. MADE IN ITALY.

DIMENSIONS

95x45x115h cm - Inch 37.4x17.7x45.3h

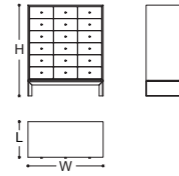

FINISHES



CANALETTO WALNUT / SATIN LIGHT BRASS



CODE: 050738 CA918 C4856

DAVID

The David range includes different storage units with drawers: a buffet (five central drawers and two columns of mock drawers hiding two doors) and a low chest of drawers (five large drawers). An internal extra moving shelf is available for the buffet option. MADE IN ITALY.

DIMENSIONS

BUFFET:

180x52x83,5h cm - Inch 70.9x20.4x32.9h

CHEST OF DRAWERS:

120x52x83,5h cm - Inch 47.2x20.4x32.9h

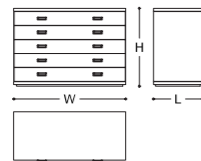

FINISHES

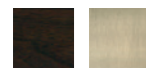

CANALETTO WALNUT / SATIN LIGHT BRASS



CODE: 048197 CA918 C5653

CASTILLA

Chest of drawers available in two sizes, with a central straight element and rounded sides. The six external drawers are easily accessible thanks to a special rotating system. All versions feature Black Maple and Technical Shagreen Fabric inside the drawers. MADE IN ITALY.

DIMENSIONS

TALL:

155x45x80h cm - Inch 61x17.7x31.5h

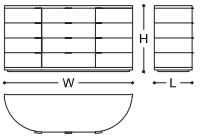

LOW:

220x45x62h cm - Inch 86.6x17.7x24.4h

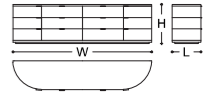

* CODE: 048060 CA867 C0020



** CODE: 048059 CA803 C0617

FINISHES

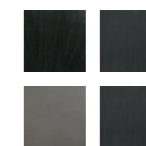

BLACK MAPLE / SATIN BLACK NICKEL *

METAL LACQUER / SATIN BLACK NICKEL **

PRESTIGE

Prestige is a sideboard developed to match the *Olimpia* bookcase. Like *Olimpia*, the structure is sustained - and lifted from the ground - by vertical tubular bars covered with leather, whose asymmetrical disposition gives movement to the entire piece. A stripe of metal, similar to a ribbon, has the double function of carrying the container unit and giving more stability to the entire sideboard. The outer frame shows joints at 45°, and is separated from the central body by an empty space to add lightness to the whole piece. The 4 doors can be opened thanks to metal knobs. *Prestige* is available in the same finishes of the *Olimpia* bookcase. **MADE IN ITALY.**

DIMENSIONS
180x45x78h cm - Inch 70.8x17.7x30.7h

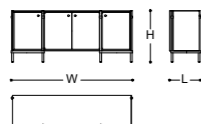

* CODE: 050381 CA941 C4856

MIRÒ

Buffet with three or four doors. The main unit of *Mirò* lies on a metal bridge structure with triangular section, like the one of the *Matrix* set of consoles. Doors feature a metal profile and push-pull opening system with slowing device; the first two doors from the left close a unique storing unit, while the last one closes a separate compartment. A middle shelf is featured in both parts. *Mirò* features an automatic inner lighting LED systems. **MADE IN ITALY.**

DIMENSIONS

THREE DOOR VERSION:
160x45x75h cm - Inch 63x17.7x29.5h

FOUR DOOR VERSION:
180x45x75h cm - Inch 70.8x17.7x29.5h

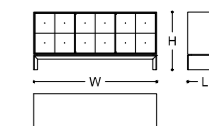

* CODE: 049332 CH464 C0136

FINISHES



FINISHES



** CODE: 045986 CA417 C0461

ANTOINETTE

The *Antoinette* iconic vanity table is characterized by a cylindrical shape with folding top and hidden seat. The outer structure in Jade Shagreen Textured Leather creates a beautiful combination with the inner parts in acrylic, inspired by natural mother-of-pearl, and Dark Green Lacquer. The seat is upholstered with Stockholm fabric, featuring a shiny/matt checkered motif. *Antoinette* features a backlit round mirror with a central switch button.

MADE IN ITALY.

DIMENSIONS

CLOSED:

Ø 70x89,5h cm - Inch Ø 27.5x35.2h

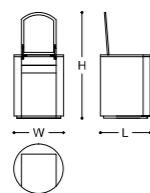

CODE: 045609 CH995 C0086

FINISHES



JADE SHAGREEN TEXTURED LEATHER /
DARK GREEN LACQUER /
STOCKHOLM FABRIC (TX180-PLATINUM)

GLAM

Glam is a coiffeuse with a simple but functional design. Its large top features curved sides and a metal outline, plus three drawers with the standard Armani/Casa handle. The top is supported by two tubular metal legs with squared section. A round mirror (diam. 40 cm) is fixed on the top and can rotate on both axes (up/down, left/right). The mirror is backlit through a LED system around the glass, that can be switched on/off thanks to a button positioned on the back. The matching stool is sold separately. MADE IN ITALY.

DIMENSIONS

COIFFEUSE:

120x50x123h cm - Inch 47.2x19.7x48.4h

STOOL:

60x40x45h cm - Inch 23.6x15.7x17.7h

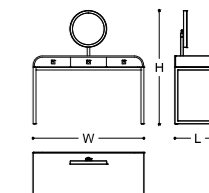

CODE: 048545 CA910 ER 130 (COIFFEUSE) / 048546 CT00A ER 130 (STOOL), TUCSON FABRIC

FINISHES



TUCSON FABRIC /
SMOKED GOLD

OMBRA

The *Ombra* screen features four panels. The lower part of each panels is empty, giving this decorative piece a lighter look. The version in Valparaiso fabric features rotating panels with fabric on one side and a mirror on the other. The main structure of this version is in metal, conceived to counterbalance the weight of the glass and hence increasing the stability of the screen.
MADE IN ITALY.

DIMENSIONS

SINGLE PANEL:
55x4x180h cm - Inch 21.6x1.5x70.9h
OPEN AT 180°:
220x4x180h cm - Inch 86.6x1.5x70.9h

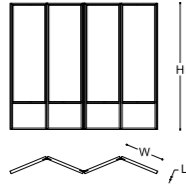

* CODE: 050114 TD082 xxxx, COLOUR TO CHOOSE



CODE: 050606 CH182 C4856

RONIN

Ronin is a tall decorative screen with three doors. The main feature of the screen is the integrated lighting system: each door is actually a LED panel with a colour of 2700 kelvin to grant a warm atmosphere. Light sources run parallel to the vertical sides of the frame of each door, hence creating a gradient effect towards the center of the doors when lit. The screen is outlined by solid walnut and each door is marked by an intertwined metal grid inspired by the armor of Japanese samurai.
MADE IN ITALY.

DIMENSIONS

SINGLE PANEL:
60x5x180h cm - Inch 23.6x1.9x70.9h
OPEN AT 180°:
180x5x180h cm - Inch 70.9x1.9x70.9h

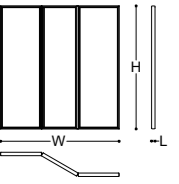

 METAL GRID /
CANALETTO WALNUT



** CODE: 050113 TD092 ER144



* CODE: 048386 CA881 C0041

DIVA

Floor standing mirror.
MADE IN ITALY.

DIMENSIONS

80x6x200h cm - Inch 31.5x2.4x78.7h

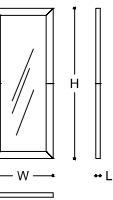

FINISHES

 CANALETTO WALNUT /
OKINAWA FABRIC (ALL COLOURS) *
 VALPARAISO FABRIC (ER144-SILVER/GREY/PALE GOLD) /
SATIN LIGHT BRASS **

FINISHES

 BLACK MAPLE
 BRUSHED BROWN OAK
 TECHNICAL SHAGREEN FABRIC *

NEMO

Towel rack in solid wood.
MADE IN ITALY.

DIMENSIONS

SMALL:
82x31x80h cm - Inch 32.3x12.2x31.5h

LARGE:
122x36x120h cm - Inch 48x14.2x47.2h

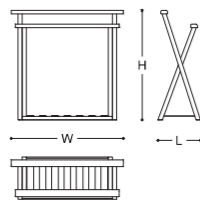

CODE: 045150 CA262 C0753 (LARGE)

FINISHES

 BRUSHED BROWN OAK

NORBERT

Cloth stand in solid wood.
MADE IN ITALY.

DIMENSIONS

44x42x105h cm - Inch 17.3x16.5x41.3h

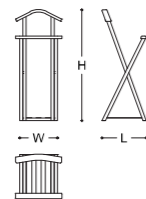

CODE: 045209 CA262 C0753

FINISHES

 BRUSHED BROWN OAK

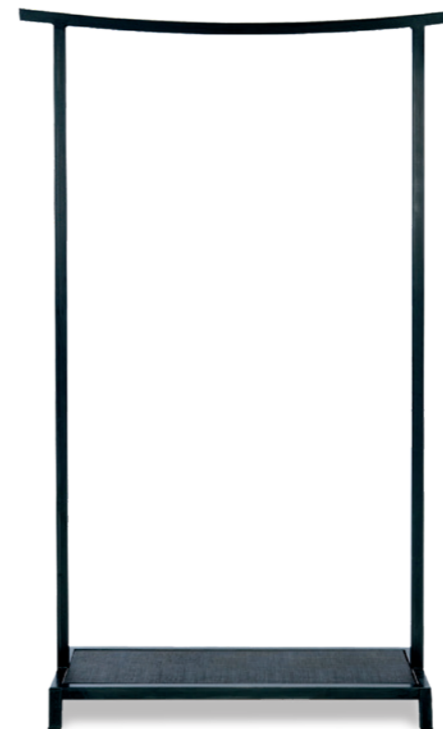

CODE: 044287 CA612 C0053

TAO

Metal rack with or without central board. The base features a central pad covered with *Tucson* fabric.
MADE IN ITALY.

DIMENSIONS

104x36x166h cm - Inch 40.9x14.2x65.3h

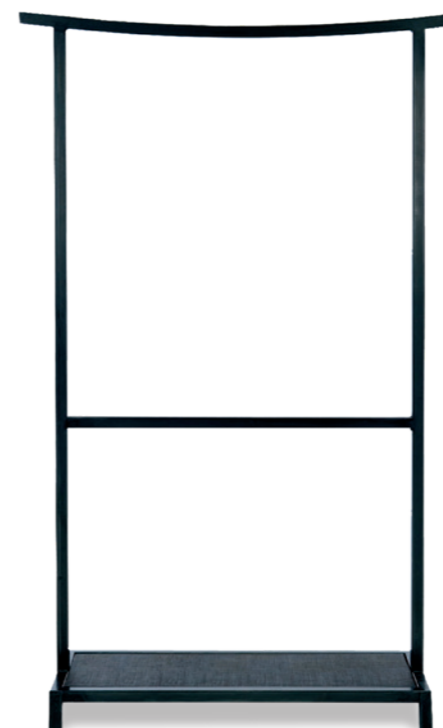
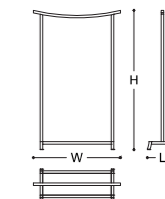

CODE: 044288 CA612 C0053

FINISHES

 PAINTED STEEL /
 TUCSON FABRIC (ER132 - ANTHRACITE)



OUTDOOR



Expression of an unmistakable aesthetic style, the outdoor collection includes everything needed to furnish three different areas: relax, sunbathing, dining. Furniture is characterized by the use of Weaved Textured Teak, a material suitable for outdoor environments and marked by a three-dimensional carving reminding the weave of textiles. To complete the look, upholsteries are available in outdoor jacquard fabrics.





TERENCE

The *Terence* sofa is part of the Armani/Casa Outdoor Collection. The structure is entirely made of solid teak wood, which is naturally weather resistant. The wood is sculpted to obtain a sinuous shape, where the tubular armrests create a single piece together with the frontal legs and the upper profile of the backrest. A particular detail is given by the three-dimensionality of the Weaved Textured Teak, a finish - used in the lower band of the structure and on the one running horizontally behind the backrest cushions - recalling the typical surface of Armani fashion fabrics. The alternance between empty spaces and the three large backrest cushions communicate a sense of lightness and comfort, emphasized by the wide seat. All upholstered parts are padded with water-repellent rubber, to ensure an optimal use outdoor. Available in all Armani/Casa outdoor fabrics; covers are removable.
MADE IN ITALY.

DIMENSIONS

2-SEAT:
170x80x73h cm - Inch 66.9x31.5x28.7h
210x100x73h cm - Inch 82.7x39.3x28.7h

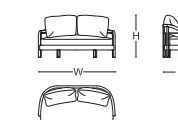

3-SEAT:
260x100x73h cm - Inch 102.3x39.3x28.7h
SH: 40 cm - Inch 15.7

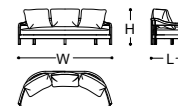

FINISHES



WEAVED TEXTURED TEAK /
TEAK



CODE: 050773 CA361 C3555 (STRUCTURE) / 051089-CT00C TO003 (CUSHIONS), TAHITI FABRIC (Note: Decorative cushions 40x40 cm are not included)



CODE: 051053 CA361 C3555 (STRUCTURE) / 051088 CT00B TO018 (CUSHIONS), TORTUGA FABRIC

TERENCE

The Terence sofa - part of the Armani/Casa Outdoor Collection - is enriched with the introduction of a modular system. It features three elements: a two seats element with left armrest, a corner element and a two seats element with right armrest. The structure is entirely made of solid teak wood, which is naturally weather resistant. The wood is sculpted to obtain a sinuous shape, where the tubular armrests create a single piece together with the frontal legs and the upper profile of the backrest. A particular detail is given by the three-dimensionality of the Weaved Textured Teak, a finish - used in the lower band of the structure and on the one running horizontally behind the backrest cushions - recalling the typical surface of Armani fashion fabrics. The alternance between empty spaces and the large backrest cushions communicate a sense of lightness and comfort, emphasized by the wide seat. All upholstered parts are padded with water-repellent rubber, to ensure an optimal use outdoor. MADE IN ITALY.

DIMENSIONS

2-SEAT ELEMENT (RIGHT/LEFT ARMREST):

184x100x73h cm - Inch 72.4x39.4x28.7h

CORNER ELEMENT:

100x100x73h cm - Inch 39.3X39.3X28.7h

SH: 40 cm - Inch 15.7



CODE: 051054 CA361 C3555 / 051056 CA361 C3555 / 051055 CA361 C3555 (STRUCTURE); 051082 CT00B TO017 / 051084 CT00B TO017 / 051083 CT00B TO017 (CUSHIONS), TORTUGA FABRIC

Composition Units

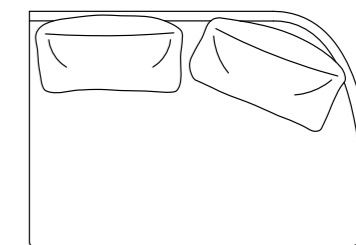
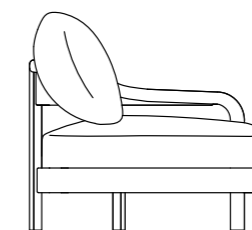
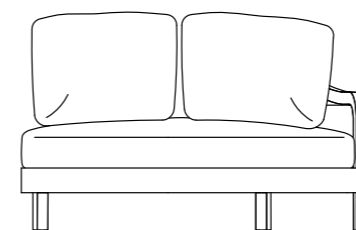

2-SEAT ELEMENT + RIGHT ARMREST

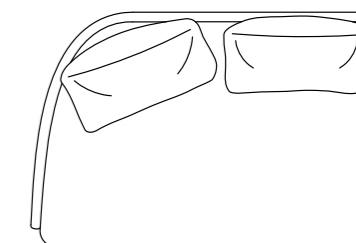
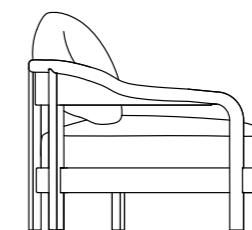
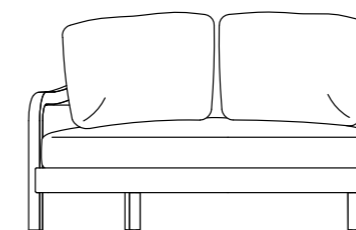

2-SEAT ELEMENT + LEFT ARMREST

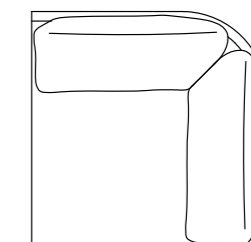
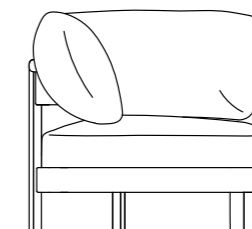
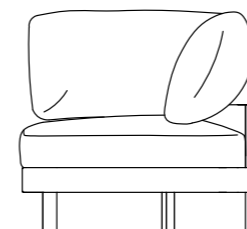

CORNER ELEMENT

TERENCE

The *Terence* range features an armchair, to match the sofa and footrest with the same name. Suitable for outdoor use, the structure is entirely made of solid teak wood, which is naturally weather resistant. The wood is sculpted to obtain a sinuous shape, where the tubular armrests create a single piece together with the frontal legs and the upper profile of the backrest. A particular detail is given by the three-dimensionality of the Weaved Textured Teak, a finish recalling the typical surface of Armani fashion fabrics. The alternance between empty spaces and the cushions communicate a sense of lightness and comfort. All upholstered parts are padded with water-repellent rubber, to ensure an optimal use outdoor. Available in all Armani/Casa outdoor fabrics; covers are removable. MADE IN ITALY.

DIMENSIONS:
83x80x75h cm - Inch 32.6x31.4x29.5h
SH: 40 cm - Inch 15.7

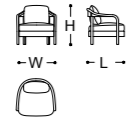

CODE: 050774 CA361 C3555 (STRUCTURE) / 051090 CT00C TO002 (CUSHIONS), TAHITI FABRIC

FINISHES

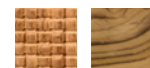

WEAVED TEXTURED TEAK /
TEAK

TERENCE

The *Terence* range also features a footrest, to match the sofa and armchair with the same name. Suitable for outdoor use, the structure is entirely made of solid teak wood, which is naturally weather resistant. A particular detail is given by the three-dimensionality of the Weaved Textured Teak, a finish recalling the typical surface of Armani fashion fabrics. All upholstered parts are padded with water-repellent rubber, to ensure an optimal use outdoor. Available in all Armani/Casa outdoor fabrics; covers are removable. MADE IN ITALY.

DIMENSIONS
83x62x40h cm - Inch 32.6x24.4x15.7h
SH: 40 cm - Inch 15.7

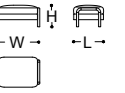

CODE: 050775 CA361 C3555 (STRUCTURE) / 051092 CT00x (CUSHION), FABRIC TO CHOOSE

FINISHES



WEAVED TEXTURED TEAK /
TEAK

THELMA

The *Thelma* chair is part of the Armani/Casa Outdoor Collection. The structure is entirely made of solid teak wood, which is naturally weather resistant. Inspired by director's chairs, *Thelma* is foldable and hence easily movable. All upholstered parts are padded with water-repellent rubber, to ensure an optimal use outdoor. *Thelma* is available in all Armani/Casa outdoor fabrics; covers are removable. MADE IN ITALY.

DIMENSIONS

56x53x78h cm - Inch 22x20.8x30.7h

SH: 45 cm - Inch 17.7

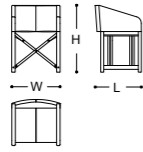

CODE: 050780 CT00C T0004, TAHITI FABRIC

FINISHES



TEAK

TURNER

The *Turner* coffee table is part of the Armani/Casa Outdoor Collection. The structure is entirely made of solid teak wood, which is naturally weather resistant. In particular, the Weaved Textured Teak recalls the typical surface of Armani fashion fabrics thanks to its three-dimensional design. *Turner* shows distinctive rounded corners, visible on the outer side of the legs and continuing on the profile of the top. The top is made with a single slab of Taj Mahal Quartzite. MADE IN ITALY.

DIMENSIONS

80x80x38h cm - Inch 31.5x31.5x14.9h

120x120x35h cm - Inch 47.2x47.2x13.7h

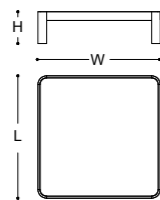

CODE: 050776 CA967 C3555

FINISHES

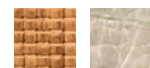

WEAVED TEXTURED TEAK /
TAJ MAHAL QUARTZITE

TERRY

Made of solid teak wood, which is naturally weather resistant, the *Terry* small tables are suitable for outdoor use. *Terry* shows X-shaped legs, a typical feature of many Armani/Casa pieces. The top - rounded or squared - is made up of wooden slats and features a relieved profile to prevent objects from falling. *Terry* is also available in a foldable version. MADE IN THAILAND.

DIMENSIONS

ROUNDED:

Ø 55x55h cm - Inch Ø 21.6x21.6h

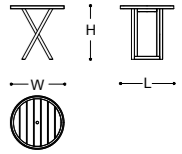

SQUARED:

50x50x55h cm - Inch 19.6x19.6x21.6h

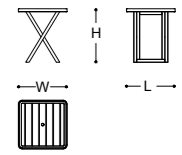

CODE: 050781 CA361 C3555



CODE: 050777 CA361 C3555

FINISHES



WEAVED TEXTURED TEAK /
TEAK (SQUARED VERSION ONLY)

TEAK

THOMAS

Thomas is a dining table suitable for outdoor use. The structure is made of solid teak wood, which is naturally weather resistant. In particular the Weaved Textured Teak, on the outer side of the legs, recalls the typical surface of Armani fashion fabrics thanks to its three-dimensional design. Thomas is available in two rectangular versions - a fixed one and an extendable one - and two round versions. The top is composed by several slats, in order to obtain a more sophisticated look. MADE IN THAILAND.

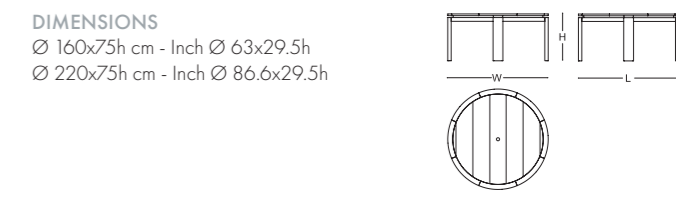
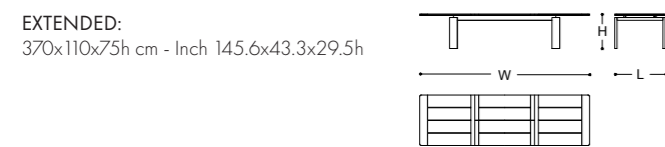
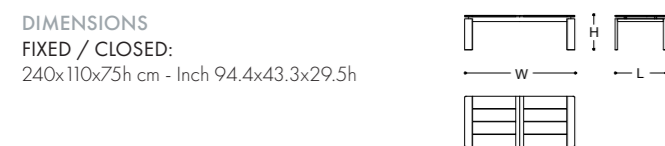

CODE: 050977 CA361 C3555



CODE: 051057 CA361 C3555

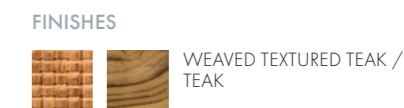
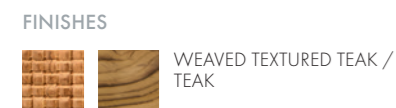

TIMOTHY

The *Timothy* sunbed is part of the Armani/Casa Outdoor Collection. The structure is entirely made of solid teak wood, which is naturally weather resistant. In particular, the Weaved Textured Teak recalls the typical surface of Armani fashion fabrics thanks to its three-dimensional design. *Timothy* - also available in a double version - shows distinctive rounded corners, visible on the outer side of the legs and continuing on the main frame around the mattress. All upholstered parts are padded with water-repellent rubber, to ensure an optimal use outdoor.
MADE IN THAILAND.

DIMENSIONS
200x73x38h cm - Inch 78.7x28.7x14.9h
SH: 42 cm - Inch 16.5

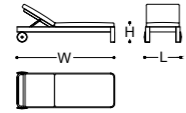

FINISHES



WEAVED TEXTURED TEAK /
TEAK

CODE: 050778 CA361 C3555 (STRUCTURE) / 051093 CT00x (CUSHIONS), FABRIC TO CHOOSE

DIMENSIONS
178x200x32.5h cm - Inch 70x78.7x12.8h
SH: 42 cm - Inch 16.5

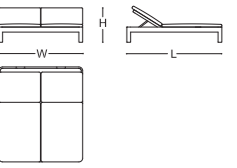

CODE: 051059 CA361 C3555 (STRUCTURE) / 051085 CT00C TO005 (CUSHIONS), TAHITI FABRIC



LIGHTING



The use of light is fundamental for Armani/Casa, a key element to design a perfect home setting in which to unwind and relax. Diffused light from multiple sources is Giorgio Armani's favorite for the home, wisely used to integrate natural light in daytime and to create cozy atmospheres at night.

Light plays also an important role in the rendition of materials, as well as in the perception of colour shades and hues. Armani/Casa lamps are conceived following those principles: their warm-toned light, together with the use of matt/transparent surfaces and finishes matching the ones used on furniture, define a perfect home setting that emphasizes the beauty of our products.





JOLANDA

Jolanda is a Murano lamp available both in the floor and table version, inspired by the shape of the traditional lanterns from the far east. The shade is completely hand made, following the ancient techniques of Murano glassmaking: a series of coloured matt glass rods are fused on a mass of white opal glass, in order to create streaks similar to those of a rock. After the process of tempering, the glass is worked by hand to get a matt finish. MADE IN ITALY.

DIMENSIONS

42x78x186,5h cm - Inch 16.5x30.7x73.4h

LIGHT TEMPERATURE

2700 kelvin

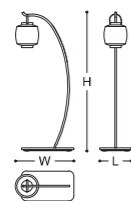

FINISHES



BRONZED BRASS /
DOVE GREY MURANO GLASS



CODE: 050027 UP008 C0454

ALADINO

Floor lamp with base and stem in Satin Black Nickel, grey or white pagoda fabric lampshade. MADE IN ITALY.

DIMENSIONS

81x48x190h cm - Inch 31.9x18.9x74.8h

LIGHT TEMPERATURE

2700 kelvin

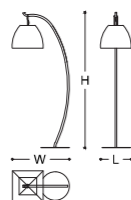

FINISHES



SATIN BLACK NICKEL



CODE: 049063 UP001 C0020 (BASE), 049064 CA236 C1040 (LAMP SHADE)

TERSILLA

Arched floor lamp with metal base and stem. Available with pagoda or cylinder fabric lampshade. MADE IN ITALY.

DIMENSIONS

189x40x209h cm - Inch 74.4x15.7x82.3h

LIGHT TEMPERATURE

2700 kelvin

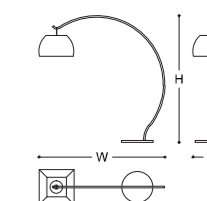

CODE: 049105 UP001 C0020 (BASE), 049106 CA236 C0010 (LAMP SHADE)

FINISHES



SATIN BLACK NICKEL

MIYA

Lamps inspired by the soft atmospheres of the Armani Privé club in Milan. All versions feature an iconic lamellar cube that filters light in a very cozy and luxurious way. The floor version is dimmable and made in wood for what concerns the base and the lamellar structure, while vertical bars and other details are in metal; it is available in two colour options. All wooden layers are painted in gold on the bottom, to increase the warm tone of the light. MADE IN ITALY.

DIMENSIONS

24x24x115h cm - Inch 9.45x9.45x45.3h
28x28x145h cm - Inch 11x11x57h

LIGHT TEMPERATURE

2700 kelvin

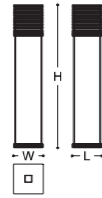

FINISHES



REA

Floor lamp inspired by the ones furnishing the halls and staircases of Palazzo Orsini in Milan, the historical palace hosting the headquarter of the Giorgio Armani company. Conceived as a metal ribbon, Rea presents thin inserts in wood on the sides. The main lighting source is located on the top part, but a second one runs on the back of the stem of the lamp: the two sources can be switched on/off and dimmed independently. Thanks to those features, the lamp irradiates a smooth cozy light. The range also includes a wall light option suitable for domotics. MADE IN ITALY.

DIMENSIONS

20x25x200h cm - Inch 7.9x9.8x78.7h

LIGHT TEMPERATURE

2700 kelvin



FINISHES



* CODE: 049347 UP005 C9553



* CODE: 045935 UP045 C2710

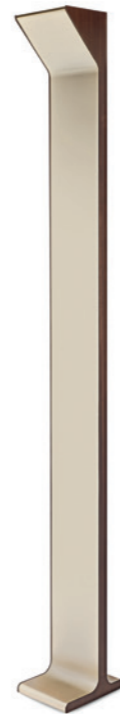

CODE: 050612 UP053 C0052



** CODE: 045935 UP056 C0251

NEMA

The Nema floor lamp features a distinctive design, whose geometric lines take inspiration from the idea of two folded paper sheets. The inner sides of the structure are available in a beautiful Shell Mosaic featuring mother-of-pearl tiles, or printed with an onyx-inspired design. Nema is bifacial, since it is finished in the same way on both sides, and it can be easily become the focal point of a room thanks to its sculptural silhouette. MADE IN ITALY.

DIMENSIONS

30x30x165h cm - Inch 11.8x11.8x64.9h

LIGHT TEMPERATURE

3000 kelvin



FINISHES



EMME

Floor lamp with a wooden base. The particular manufacturing of the three legs reinterprets the classic tripod stand lamp in a modern style marked by a high level of craftsmanship: starting from a squared section at the bottom, the legs intersect at the top creating a triangular shape. Truncated cone lampshade in white fabric, with diffuser disc in the lower part. MADE IN ITALY.

DIMENSIONS

Ø 53x191h cm - Inch Ø 20.9x75.2h

LIGHT TEMPERATURE

2700 kelvin

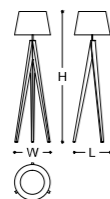

* CODE: 049091 UP006 C0020 (BASE), 049092 CA236 C0010 (LAMP SHADE)

FINISHES



BLACK MAPLE /
GLOSSY NATURAL BRASS

RAMAGE

Floor lamp with tripod structure. The legs are conceived to reproduce three bamboo canes in metal, hence making this lamp matchable with the Pamela range. Shade with truncated cone shape, in fabric or in a special micro-perforated elm wood. The intricate design of the latter is inspired by wicker patterns, and creates a special seethrough effect with geometrical reflections of the light. The wood of this shade is coupled with a inner layer of PVC and features decorative metal rings on the borders, as well as two diffuser discs (above and below the light source); the fabric shade, instead, features a upper diffuser disc only. MADE IN ITALY.

DIMENSIONS

Ø 50x175h cm - Inch Ø 19.6x68.8h

LIGHT TEMPERATURE

2700 kelvin

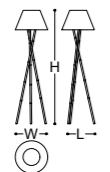

CODE: 050611 UP037 C0052 (BASE), 050396 CA236 C0010 (LAMP SHADE)

FINISHES



SATIN LIGHT BRASS



CODE: 050395 UP037 C0052 (BASE), 050396 CA236 C0010 (LAMP SHADE)

PAMELA

Pamela is a lamp available both in table and floor version. The distinctive feature of this lamp is the thin metal stem, sculpted to resemble a bamboo cane and connected to a circular base developed on more levels. On the table version, the switch/dimmer - featuring the GA logo and a touch technology - is located on the base; on the floor version, it can be found on the stem. Available with truncated cone shade in fabric or in a special micro-perforated elm wood. The intricate design of the latter is inspired by wicker patterns, and creates a special see-through effect with geometrical reflections of the light. The wood of this shade is coupled with a inner layer of PVC and features decorative metal rings on the borders, as well as two diffuser discs (above and below the light source); the fabric shade, instead, features a upper disc only. MADE IN ITALY.

DIMENSIONS

Ø 50x182h cm - Inch Ø 19.7x71.6h

LIGHT TEMPERATURE

2700 kelvin

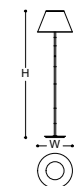

FINISHES



SATIN LIGHT BRASS

RETTA

Floor lamp inspired the shape of two bamboo canes, made of metal. The light sources are two: one is located on the top of the vertical cane, while another is on the end of the shorter cane. The shorter cane can rotate around its horizontal axis in order to be used as a spot light for reading. MADE IN ITALY.

DIMENSIONS

105x20x170h cm - Inch 41.3x7.8x66.9h

LIGHT TEMPERATURE

2700 kelvin

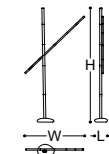

CODE: 050614 UP037 C0052

FINISHES



SATIN LIGHT BRASS

ALICE

Alice is an adjustable floor lamp with base in Canaletto Walnut with squared section. The central part of the stem is either clad in Natural Thin Leather or Dove Grey Thin Leather, while the telescopic part is in Satin Light Brass. Shade in standard ivory fabric.
MADE IN ITALY.

DIMENSIONS
90x42x150h cm - Inch 35.4x16.5x59h

LIGHT TEMPERATURE
2700 kelvin

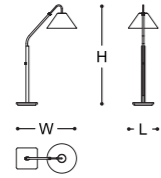

* CODE: 051191 UP065 C4856



** CODE: 051191 UP065 C4856

FINISHES



NEXT

Reading floor lamp with brass structure and black painted base in steel. The stem is divided in two segments that, together with the upper part, grant the best possible orientation of the lamp. A decorative - and removable - truncated cone shade in coloured fabric (white, beige or gold) envelops the light source. Large metal GA logo on the base.
MADE IN ITALY.

DIMENSIONS
10x65x150h cm - Inch 3.9x25.5x59h

LIGHT TEMPERATURE
2700 kelvin

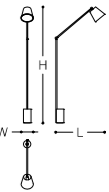

CODE: 045651 UP035 C0010



* CODE: 045616 UP028 C0086

FINISHES

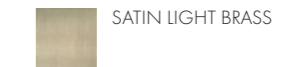

NIGHT

Reading floor lamp with V-shaped shade. The whole structure is in brass with the shade and the stem covered with leather. The shade can be oriented and features an on/off switch integrated on the back. The intensity of the light can be adjusted.
MADE IN ITALY.

DIMENSIONS
36x16x145h cm - Inch 14.1x6.2x57h

LIGHT TEMPERATURE
2700 kelvin

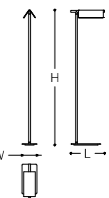

FINISHES



LOGO

This table lamp was the very first product ever designed for Armani/Casa, back in 1982, by Giorgio Armani himself: for this reason, it became the logo of the brand. The satinated black metal structure features a lampshade in the shape of a truncated pyramid, made of ivory metachrylate. MADE IN ITALY.

DIMENSIONS

48x48x82,3h cm - Inch 18.9x18.9x32.4h

LIGHT TEMPERATURE

2700 kelvin

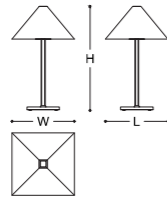

FINISHES

 SATIN BLACK NICKEL



CODE: 045532 UP001 C2020

LOGO Mini

The very first home product designed by Giorgio Armani, the iconic *Logo* lamp, is presented in a "mini" version that can be used in different situations: as table lamp on bedside tables, for example, or to create a warm atmosphere while having dinner. Switch/dimmer on the metal base. *Logo Mini* is rechargeable and requires a power supply box (included) to work; this cable features a charger with USB. MADE IN ITALY.

DIMENSIONS

15x15x24h cm - Inch 5.9x5.9x9.4h

LIGHT TEMPERATURE

3000 kelvin

BATTERY DEVICE

Recharge time: 2 hours

Autonomy at maximum light: 7 hours



FINISHES

 GOLDEN METHACRYLATE / SATIN LIGHT BRASS



CODE: 050129 UP044 C0161

LOGO (Lamellar lampshade)

The iconic *Logo* table lamp is presented in a new version, with a lampshade inspired by the soft atmospheres of the *Armani Privé* club in Milan. The shade has been reinterpreted with a lamellar pyramid that filters light in a very cozy and luxurious way. This version of *Logo* is smaller than the traditional one, in order to easily fit different kinds of rooms and settings. Available in two finishes both with Satin Light Brass details. MADE IN ITALY.

DIMENSIONS

40x40x64h cm - Inch 17.7x15.7x25.2h

LIGHT TEMPERATURE

2700 kelvin

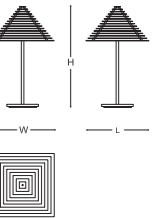

* CODE: 051050 UP064 C4856



** CODE: 051049 UP059 00151

FINISHES

 CANALETTO WALNUT / SATIN LIGHT BRASS *

 SATIN LIGHT BRASS **

CHERIE

Table lamp with rectangular base in metal and GA logo-shaped stem. The laser carved letters in metal surround an element covered in dark brown leather with lizard print. Truncated pyramid shade in grey or bronze fabric. MADE IN ITALY.

DIMENSIONS

Ø 48x69h cm - Inch Ø 18.9x27.2h

LIGHT TEMPERATURE

2700 kelvin

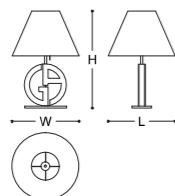

CODE: 049078 UP011 C0020 (BASE), 049072 CA236 C1844 (LAMP SHADE)

FINISHES

SATIN BLACK NICKEL

PAMELA

Pamela is a lamp available both in table and floor version. The distinctive feature of this lamp is the thin metal stem, sculpted to resemble a bamboo cane and connected to a circular base developed on more levels. On the table version, the switch/dimmer - featuring the GA logo and a touch technology - is located on the base; on the floor version, it can be found on the stem. Available with truncated cone shade in fabric or in a special micro-perforated elm wood. The intricate design of the latter is inspired by wicker patterns, and creates a special see-through effect with geometrical reflections of the light. The wood of this shade is coupled with an inner layer of PVC and features decorative metal rings on the borders, as well as two diffuser discs (above and below the light source); the fabric shade, instead, features an upper disc only. MADE IN ITALY.

DIMENSIONS

Ø 42x67h cm - Inch Ø 16.5x26.4h

LIGHT TEMPERATURE

2700 kelvin

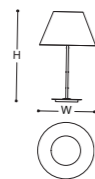

CODE: 050393 UP037 C0052 (BASE), 050394 CA236 C0010 (LAMP SHADE)

FINISHES

SATIN LIGHT BRASS

GILDA

Gilda is a table lamp with a Murano glass base. The base is produced by a traditional process in the furnace, in which several layers of coloured glass are superimposed to create this effect that will be different in every piece. Then it is blown individually in a mold determining the shape. After the tempering process the glass it is passed by a band to obtain the matt finish. The shade is a truncated cone with top diffuser disc, available in white fabric only. The base is lit internally thanks to a LED system that can be switched on/off independently from the lampshade. MADE IN ITALY.

DIMENSIONS

Ø 39x57,5h cm - Inch Ø 15.4x22.6h

LIGHT TEMPERATURE

2700 kelvin

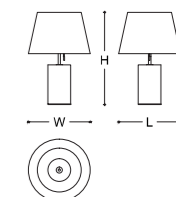

CODE: 049110 UP027 C0099 (BASE), 049111 CA236 C0010 (LAMP SHADE)

FINISHES

SUNSET MURANO GLASS / SATIN LIGHT BRASS

PALADINO

Paladino is a table lamp born from the idea of a three-dimensional *canneté* developed vertically; for this reason, the finish selected for this product is Brass Carved Liquid Metal, already an Armani/Casa icon. Liquid metal is a special lacquer made with real metal pigments, which give the finish the typical reflectance of real metal and its cold touch. Depending on the support, it is possible to obtain different effects: the carved version featured here creates the illusion of vintage brass rods. Available with truncated cone shade in fabric (white) with upper diffuser disc. MADE IN ITALY.

DIMENSIONS

Ø 45x57h cm - Inch Ø 17.7x22.4h

LIGHT TEMPERATURE

2700 kelvin

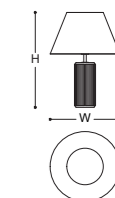

CODE: 050388 UP049 C2456 (BASE), 050394 CA236 C0010 (LAMP SHADE)

FINISHES

BRASS CARVED LIQUID METAL / SATIN LIGHT BRASS

BLOOM

Table lamp with base in polished onyx with metal details. The base is lit internally thanks to a led system that can be switched on/off independently from the lampshade. The pagoda-shaped lampshade is available in cream colour only. MADE IN ITALY.

DIMENSIONS
48x48x75h cm - Inch 18.9x18.9x29.5h

LIGHT TEMPERATURE
2700 kelvin

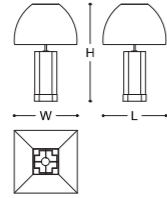

FINISHES



CODE: 049108 UP026 C0012 (BASE), 049109 CA236 C0012 (LAMP SHADE)

DONNA

Donna is a table lamp featuring the same base design as the *Hope* wall light. It features a truncated pyramid-shaped shade in white fabric. Top diffuser disc. MADE IN ITALY.

DIMENSIONS
40x40x59,5h cm - Inch 15.8x15.8x23.4h

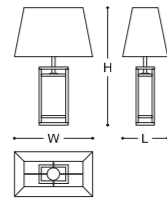

FINISHES



CODE: 049080 UP013 C0461 (BASE), 049082 CA236 C0010 (LAMP SHADE)

DORY

Table lamp with rectangular base. The two large faces with vertical orientation are clad with reptile-printed leather in cream colour, while the sides are refined by large borders in golden metal. Truncated cone shade in white fabric. Top diffuser disc. MADE IN ITALY.

DIMENSIONS
Ø 42x60h cm - Inch Ø 16.5x23.6h

LIGHT TEMPERATURE
2700 kelvin

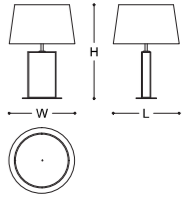

FINISHES



CODE: 049087 UP016 C0051 (BASE), 049084 CA236 C0010 (LAMP SHADE)

TESSA

Tessa is a table lamp marked by a truncated cone base, clad in Cognac Thin Leather. The lampshade can be selected in two shapes - truncated cone or cylindrical - available in white fabric. Metal details are in Satin Light Brass. MADE IN ITALY.

DIMENSIONS
Ø 39x57h cm - Inch Ø 15.3x22.4h

LIGHT TEMPERATURE
2700 kelvin

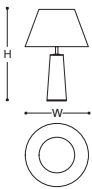

FINISHES



CODE: 050784 UP028 00151 (BASE), 050785 CA236 C0010 (LAMP SHADE)

TIMEA

The table lamp *Timea* stands out for its monolithic base with rounded corners. The same shape is replicated on the lampshade in fabric. The base of the lamp is entirely covered with Thin Leather, available in two colors - Cognac and Dove Grey - with visible stitchings and enriched by a GA logo in Satin Light Brass like all the other metal details. Timea is dimmable and presents an on/off switch located on the structure. MADE IN ITALY.

DIMENSIONS

28x20x47h cm - Inch 11x7.8x 18.5h

LIGHT TEMPERATURE

2700 kelvin

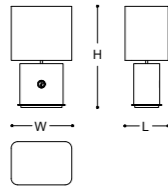

* CODE: 050790 UP028 00151

FINISHES



COGNAC THIN LEATHER / SATIN LIGHT BRASS *

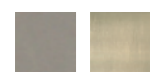

DOVE GREY THIN LEATHER / SATIN LIGHT BRASS **



** CODE: 050790 UP028 C0554

RONNIE

Table lamp with black aluminium structure and fabric shade. The use of aluminum makes this lamp less heavy and easier to move. The structure features the same detail marking the *Play* range of coffee/small tables, with joints on the edges becoming a distinctive decoration motif. Handle in brass, covered with thick leather (cuoio). MADE IN ITALY.

DIMENSIONS

26x20x65h cm - Inch 10.2x7.8x25.6h

LIGHT TEMPERATURE

2700 kelvin

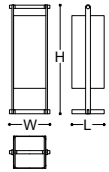

CODE: 050609 UP052 C4856

FINISHES



COGNAC LEATHER (CUOIO) / SATIN LIGHT BRASS

VISTA

Vista is a table lamp inspired by a Japanese taste, featuring a cylindrical shade in fabric with the print of a mountain landscape fading in the mist: this design is the same marking the *Travis* rug and the *Basho* wallcovering by Armani/Casa. The base is a circle in Satin Light Brass, supporting two ribbon-shaped uprights jointed by a cylindrical top handle in the same metal.

MADE IN ITALY.

DIMENSIONS

∅ 20x52h cm - Inch ∅ 7.8x20.5h

LIGHT TEMPERATURE

2700 kelvin

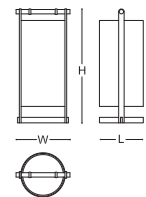

CODE: 051077 UP061 C0010

FINISHES



SATIN LIGHT BRASS

ANTHEA

Anthea is a table lamp with a strong Art Déco inspiration, made of Satin Light Brass and Selenite. The rectangular slabs of the stone have different lengths and, thanks to their pearlescent appearance, diffuse light in a very particular yet luxurious way. Another typical feature of Moroccan selenite is having crystals disposed on different planes, which determine the irregularity of the surface – even when cut – hence emphasizing the three-dimensionality. Anthea presents a switch/dimmer located on the base, in the shape of a rounded GA logo. MADE IN ITALY.

DIMENSIONS
32x16x28h cm - Inch 12.6x6.3x11h

LIGHT TEMPERATURE
3000 kelvin

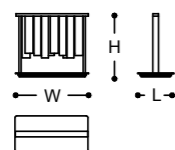

FINISHES



SATIN LIGHT BRASS /
SELENITE

NIGHT

Reading table lamp with V-shaped shade. The whole structure is in brass with the shade and the stem covered with leather. The shade can be oriented and features an on/off switch integrated on the back. The intensity of the light can be adjusted. MADE IN ITALY.

DIMENSIONS
13x34x35h cm - Inch 5.1x13.3x13.7h

LIGHT TEMPERATURE
2700 kelvin

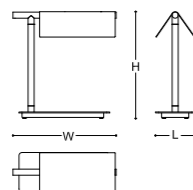

FINISHES



DARK GREEN THIN LEATHER /
SATIN LIGHT BRASS

DOVE GREY THIN LEATHER /
SATIN LIGHT BRASS *



CODE: 051210 UP066 C6210



* CODE: 045616 UP028 C0554

NEXT

Reading table lamp with brass structure and rectangular flat base in steel. The stem is divided in two leather-covered segments that, together with the upper part, grant the best possible orientation of the lamp. A decorative truncated cone shade in coloured fabric (white, beige or gold) envelops the light source. Large metal GA logo on the base. Switch/dimmer in the shape of GA logo on the base. MADE IN ITALY.

DIMENSIONS
20x57x58h cm - Inch 7.8x22.4x22.8h

LIGHT TEMPERATURE
2700 kelvin

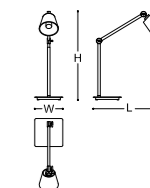

FINISHES



NATURAL THIN LEATHER /
SATIN LIGHT BRASS



CODE: 050134 UP028 C0010



CODE: 049057 UP028 C0086

NORIKO

Table lamp with base and shade in leather and details in brass. The cylindrical base contains the LED system, which is totally invisible from the side view. The shade can be oriented on the horizontal axis. Touch switch in the shape of a small GA logo in metal, located in the lower part of the base. MADE IN ITALY.

DIMENSIONS
15x43x40h cm - Inch 5.9x16.9x15.7h

LIGHT TEMPERATURE
2700 kelvin

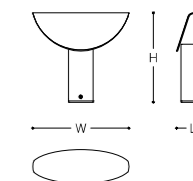

FINISHES



DARK GREEN THIN LEATHER /
SATIN LIGHT BRASS

HYADES

Hyades is inspired by the shape of the classical lanterns from the Far East and it is completely hand made following the ancient techniques of Murano glassmaking. The glass shade is produced by a traditional process in the furnace, where a series of coloured glass rods are fused on a mass that is superimposed on an internal layer of white opal glass in order to create a series of veins similar to those of marble. After the tempering process the glass it is passed by a band to obtain the matt finish.
MADE IN ITALY.

DIMENSIONS
Ø 36x49h cm - Inch Ø 14.2x19.3h
LIGHT TEMPERATURE
2700 kelvin

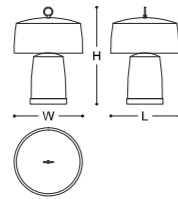

CODE: 048917 UP023 C0454

FINISHES

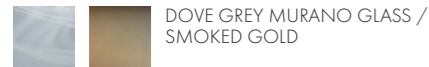

JOLANDA

The shade of *Jolanda* is made completely by hand, following the ancient techniques of Murano glassmaking. The glass shade is produced by a traditional process in the furnace, where a series of coloured glass rods are fused on a mass that is superimposed on an internal layer of white opal glass in order to create a series of veins similar to those of marble.
MADE IN ITALY.

DIMENSIONS
Ø 31x45h cm - Inch Ø 12.2x17.7h
LIGHT TEMPERATURE
2700 kelvin

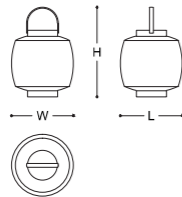

CODE: 050026 UP008 C0454

FINISHES



ALABASTER

Cubic table lamp with wooden base and streaked onyx lampshade.
MADE IN ITALY.

DIMENSIONS
26x26x26h cm - Inch 10.2x10.2x10.2h
LIGHT TEMPERATURE
2700 kelvin

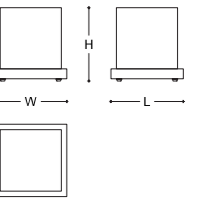

CODE: 048205 UP058 C0010

FINISHES



DIogene

Table lamp inspired to Eastern lanterns with structure in wood and metal.
Available with the shade in black grid fabric.
MADE IN ITALY.

DIMENSIONS
24,5x24,5x48,5h cm - Inch 9.7x9.7x19.1h
LIGHT TEMPERATURE
2700 kelvin

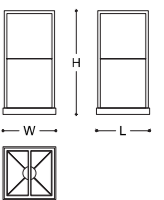

CODE: 045530 UP012 C0020

FINISHES

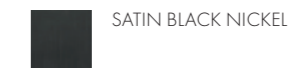

MIYA

Lamps inspired by the soft atmospheres of the *Armani Privé* club in Milan. All versions feature an iconic lamellar cube that filters light in a very cozy and luxurious way. The table version is dimmable and made in wood for what concerns the base and the lamellar structure, while vertical bars and other details are in metal; it is available in two colour options. All wooden layers are painted in gold on the bottom, to increase the warm tone of the light. The lantern version (large and small), instead, is in greige lacquer and has a LED working with a battery device.
MADE IN ITALY.

DIMENSIONS

TABLE LAMP:

20x20x46h cm - Inch 7.9x7.9x18.1h

LARGE LANTERN:

20x20x26h cm - Inch 7.9x7.9x10.2h

SMALL LANTERN:

12x12x17h cm - Inch 4.7x4.7x6.7h

LIGHT TEMPERATURE

2700 kelvin

BATTERY DEVICE (lanterns only)

Recharge time: 3 hours

Autonomy at maximum light: 8 hours

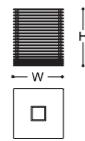
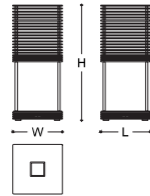

* CODE: 049346 UP005 C9553 (TABLE LAMP)



** CODE: 050392 UP015 C0356 (LARGE LANTERN)



** CODE: 049345 UP015 C0356 (SMALL LANTERN)

FINISHES

  CANALETTO WALNUT / SATIN LIGHT BRASS (TABLE LAMP) *

 SATIN LIGHT BRASS **

VOLTA

Named after the Italian physicist Alessandro Volta, this table lamp tributes the inventor of the electrical battery with its modern design. The base and the upper part - in Satin Light Brass - have the shape of low cylinders, connected by a stem in Satin Light Brass enveloped in a methacrylate tube. The stem seem to pierce the upper cylinder, where the light source is contained, and thanks to the transparency of the methacrylate, light is partially visible also through this detail. Volta is available in three dimensions; the smaller one is rechargeable and requires a power supply box (included) to work. *Volta* is dimmable and presents an on/off switch located on the structure.
MADE IN ITALY.

DIMENSIONS

SMALL:

Ø 16x30h cm - Inch Ø 6.3x11.8h

MEDIUM:

Ø 27x36h cm - Inch Ø 10.6x14.2h

LARGE:

Ø 35x45h cm - Inch Ø 13.7x17.7h

LIGHT TEMPERATURE

2700 kelvin

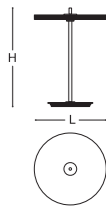

CODE: 051073 UP062 C0052

FINISHES

  SATIN LIGHT BRASS / TRANSPARENT METHACRYLATE

TOPAZIO

The *Topazio* wall light inspired a rechargeable lantern with the same shape. The inspiration comes from a classic faceted cut for gems - hence the name of the product - combined with contemporary materials. The lamp is visually light thanks to the open sides, framed by a metal structure in champagne colour. When lit, *Topazio* creates a beautiful effect thanks to light reflecting on multiple surfaces and projecting particular geometric shades.
MADE IN ITALY.

*Note: the lamp is not waterproof.

DIMENSIONS

20x20x34h cm - Inch 7.9x7.9x13.4h

LIGHT TEMPERATURE

2700 kelvin

BATTERY DEVICE

Recharge time: 3 hours

Autonomy at maximum light: 8 hours

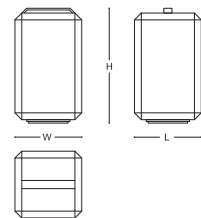

CODE: 051071 UP060 C 1255

FINISHES

 CHAMPAGNE METAL

NELLY

Rechargeable wireless lantern. *Nelly* is lit through a LED light placed below the top part, completely invisible from the side view and powered by a battery system. Switch in brass placed on the top. Moving this lamp is easy thanks to the large handle in metal: in this way, *Nelly* can be used also outdoor*.
MADE IN ITALY.

*Note: the lamp is not waterproof.

DIMENSIONS
15x15x42h cm - Inch 5.9x5.9x16.5h

LIGHT TEMPERATURE
2700 kelvin

BATTERY DEVICE
Recharge time: 3 hours
Autonomy at maximum light: 8 hours

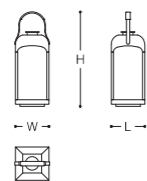

FINISHES

 SATIN LIGHT BRASS



CODE: 045313 UP028 C0086

SIBILLA

Sibilla is a tiny cubic lamp mixing Giorgio Armani's favourite shape - the square - with the monogram featuring his initials. The GA logo is reproduced in series in order to build the entire shade of the lantern, lit by a cozy warm light and projecting the logo all around. Switch/dimmer on the metal base. *Sibilla* is rechargeable and has a LED working with a battery device.
MADE IN ITALY.

DIMENSIONS
11,5x11,5x14,5h cm - Inch 4.5x4.5x5.7h

LIGHT TEMPERATURE
2700 kelvin

BATTERY DEVICE
Recharge time: 3 hours
Autonomy at maximum light: 8 hours



CODE: 050716 UP015 C0056

PICNIC

Picnic features a bamboo-shaped handle (fixed) and a switch/dimmer located in the upper part. The sides are in transparent methacrylate and show a decoration with concentric rectangles, obtained thanks to a laser engraving in the methacrylate itself: in this way, the lantern creates a particular effect when lit. Available in two sizes, *Picnic* is presented in a special metal in champagne colour developed for this range only. The inner cylinder - containing the LED lighting source - is in natural alabaster.
MADE IN ITALY.

DIMENSIONS
SMALL VERSION:
15x15x29h cm - Inch 5.9x5.9x11.4h

LARGE VERSION:
25x25x48h cm - Inch 9.8x9.8x18.9h

LIGHT TEMPERATURE
2700 kelvin

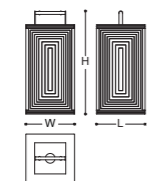

FINISHES

 CHAMPAGNE METAL /
TRANSPARENT METHACRYLATE



CODE: 050390 UP050 C 1255 (LARGE LANTERN), 050391 UP050 C 1255 (SMALL LANTERN)

TRILLY

Trilly is a rechargeable lantern made with intertwined metal, available in two sizes. Both feature an upper handle to make them easier to move. The LED light source is contained in a cylinder in opaline methacrylate, which creates a more diffused effect. GA logo on the upper part. The switch is located below the base.
MADE IN ITALY.

DIMENSIONS
SMALL VERSION:
Ø 23x33h cm - Inch Ø 9x12h

LARGE VERSION:
Ø 40x51h cm - Inch Ø 15.7x20h

LIGHT TEMPERATURE
2700 kelvin

BATTERY DEVICE
Recharge time: 3 hours
Autonomy at maximum light: 8 hours

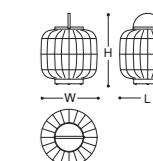

CODE: 050792 UP037 C0052 (LARGE LANTERN), 050791 UP037 C0052 (SMALL LANTERN)

HOPE

Hope was designed by Armani/Casa for the private residences of Giorgio Armani, the Armani Hotels and the projects of the Interior Design Service of Armani/Casa. The structure of this wall light is taken from the base of the *Donna* table lamp. The structure is in metal with the diffuser in white fabric. *Hope* features a hook on the back to fix it easily on the wall. MADE IN ITALY.

DIMENSIONS
15x10,5x30h cm - Inch 5.9x4.1x11.8h
LIGHT TEMPERATURE
2700 kelvin

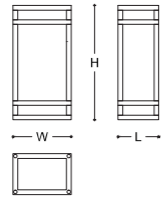

FINISHES

 SMOKED GOLD



CODE: 048693 UP019 C0010

TOPAZIO

The design of the *Topazio* wall light is a perfect balance between tradition and innovation: the inspiration came from a classic faceted cut for gems - hence the name of the product - while the look and the materials are extremely contemporary. *Topazio* is visually light thanks to the open sides, framed by the structure in Champagne Metal. The LED light sources are invisible from all observation angles once the light is fixed on the wall, since they are located on the inner side of the vertical parts of the structure. The combination of all those elements creates a beautiful effect when *Topazio* is lit, with light reflecting on multiple surfaces and projecting particular geometric shades. MADE IN ITALY.

DIMENSIONS
18x12x29h cm - Inch 7x4.7x11.4h
LIGHT TEMPERATURE
2700 kelvin

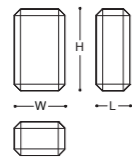

FINISHES

 CHAMPAGNE METAL



CODE: 050794 UP050 C 1255

REA

Wall light inspired by the lamps furnishing the halls and staircases of Palazzo Orsini in Milan, the historical palace hosting the headquarter of the *Giorgio Armani* company. *Rea* presents thin inserts in wood on the sides. *Rea* is suitable for domotics. MADE IN ITALY.

DIMENSIONS
20x14x14h cm - Inch 7.8x5.5x5.5h
LIGHT TEMPERATURE
2700 kelvin

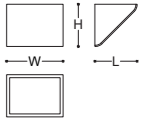

FINISHES

 CANALETTO WALNUT /
 SATIN LIGHT BRASS

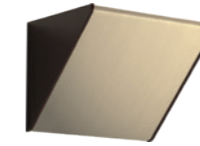

CODE: 050613 UP053 C0052

POWER SUPPLY BOXES

All Armani/Casa lamps work thanks to a LED system, which requires a specific power supply box. Depending on the lamp, different boxes can be available; each power supply box comes with three interchangeable plugs (CEE, UK, US). Please check the current Pricelist for further information.

030146 CA220 C0020 – Cable for table lamp with on/off switch, total length 1.8 mt

030147 CA220 C0020 – Cable for floor lamp with on/off switch, total length 1.8 mt

030148 CA220 C0020 – Cable without switch, total length 1.8 mt

030149 CA220 C0020 – Cable for table lamp with dimmer, total length 1.8 mt

030150 CA220 C0020 – Cable for floor lamp with dimmer, total length 1.8 mt

TECHNICAL DATA

LED lifespan: 50,000 hours.

Input: 100-240V ~ 0.7A, 50-60Hz

For indoor use only.

RANGE NAME	TYPE	MATCHING POWER SUPPLY BOX				
		030146	030147	030148	030149	030150
ALABASTER	Table			X		
ALADINO	Floor		X			X
ALICE	Floor		X			X
ANTHEA	Table			X		X
BLOOM	Table			X		
CHERIE	Table	X			X	
DIOGENE	Table	X			X	
DONNA	Table	X			X	
DORY	Table	X			X	
EMME	Floor		X			X
GILDA	Table			X		
HOPE	Wall light	none				
HYADES	Table	X			X	
JOLANDA	Floor			X		
JOLANDA	Table			X		
LOGO	Table	X			X	
LOGO (Lamellar lampshade)	Table			X		
LOGO MINI	Lantern	none				
MIYA	Floor			X		
MIYA	Lanterns			X		
MIYA	Table			X		
NELLY	Lantern			X		
NEMA	Floor			X		
NEXT	Floor		X			X
NEXT	Table			X		

RANGE NAME	TYPE	MATCHING POWER SUPPLY BOX				
		030146	030147	030148	030149	030150
NIGHT	Floor			X		
NIGHT	Table			X		
NORIKO	Table			X		
PALADINO	Table	X			X	
PAMELA	Floor			X		
PAMELA	Table			X		
PICNIC	Lantern			X		
RAMAGE	Floor			X		
REA	Floor			X		
REA	Wall light	none				
RETTA	Floor			X		
RONNIE	Table	X			X	
SIBILLA	Lantern			X		
TERSILLA	Floor		X			X
TESSA	Table	X			X	
TIMEA	Table			X		
TOPAZIO	Table			X		
TOPAZIO	Wall light	none				
TRILLY	Lantern			X		
VISTA	Table	X			X	
VOLTA	Table			X		
VOLTA	Lantern	none				



RUGS & MATS



Most of Armani/Casa rugs are entirely handmade by Nepalese artisans who master the traditional technique of hand-knotting. The high density, together with the use of different yarns in terms of colour and composition, permits to obtain exceptional quality and aesthetics.

The dyeing of the yarns is made by hand and with a constant comparison to master samples, in order to reduce the discrepancy that naturally occurs from lot to lot. Once all yarns are ready, artisans begin the knotting: only the most skillful artisans can work on Armani/Casa designs, since their incredibly rich scales of shaded colours need frequent changes of yarn that can be managed only by the best long-experienced knotters.

After the knotting, each rug is washed and dried to revive colours. The drying phase is carried out in open-air environments to avoid aggressive treatments that could compromise the quality of the fibers. If the carpet features an accentuated three-dimensionality of the surface, a final scissor cutting is performed by hand.

The Armani/Casa collection of rugs comprises also loom-woven options.



ARMSTRONG

Striped rug reinterpreting the *canneté* motif typical of the Armani style, available in custom size. Density: 100 knots/squared inch. The carpet is hand knotted without any child labour.
MADE IN NEPAL.

DIMENSIONS

Custom size

MATERIALS

50% SILK / 50% WOOL

OTHER COLOURS



STEEL BLUE



PEARL



SAND



IVORY / BLACK

BURT

Rug with discontinued multistriped motif, available in custom size. Density: 100 knots/squared inch. The carpet is hand knotted without any child labour.
MADE IN NEPAL.

DIMENSIONS

Custom size

MATERIALS

100% SILK

BAX

Rug with geometric Art Déco motif, available in custom size. Density: 100 knots/squared inch. The carpet is hand knotted without any child labour.
MADE IN NEPAL.

DIMENSIONS

Custom size

MATERIALS

50% WOOL / 30% MATKA SILK / 20% SILK

OTHER COLOURS



PEARL



IVORY / DARK BROWN



GREY / BEIGE

CADRE

Rug with striped effect and contrasting frame, available in custom size. The delicate tone-on-tone narrow-stripe effect is obtained thanks to the use of two different techniques: bouclé wool and cut-pile viscose. The contrast between the alternating glossy and matt yarns adds a sophisticated touch to the contemporary decoration. Density: 100 knots/squared inch. The carpet is hand knotted without any child labour.
MADE IN NEPAL.

DIMENSIONS

Custom size

MATERIALS

62% VISCOSE / 38% WOOL

CHAPLIN

Carpet with mélange effect, available in custom size. The sober look is given by the richness obtained through the matching of two different yarn colours. Density: 100 knots/squared inch. The carpet is hand knotted without any child labour.
MADE IN NEPAL.

DIMENSIONS

Custom size

MATERIALS

100% VISCOSE



GREY / ANTHRACITE

CRONOS

Rug with tone-on-tone moiré effect, available in custom size. Cronos emphasizes the subtle link to the world of fabrics and hints at the precious materials marking Armani/Casa furniture through the imitation of wood grain patterns. Density: 100 knots/squared inch. The carpet is hand knotted without any child labour.
MADE IN NEPAL.

DIMENSIONS

Custom size

MATERIALS

50% SILK / 50% WOOL

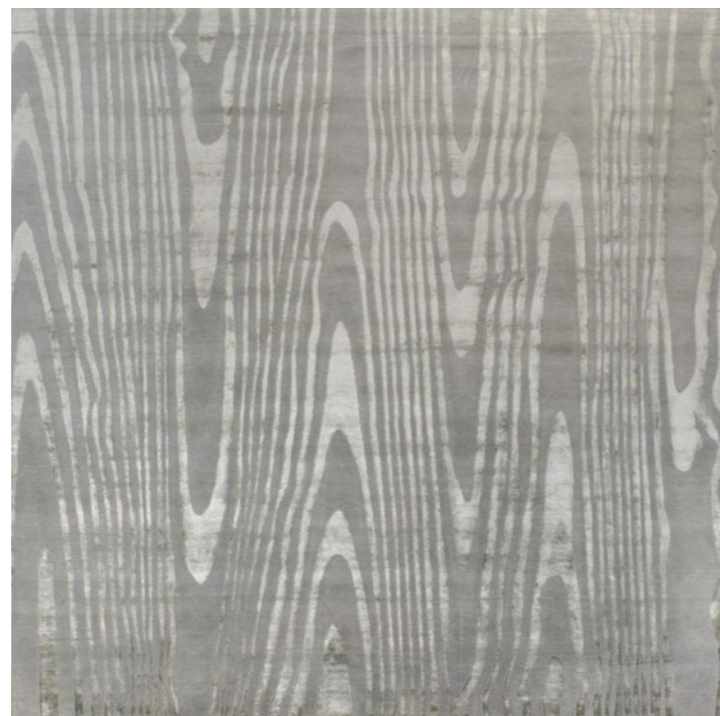

OLIVE GREY



BEIGE

CROQUIS

Rug with an Art Déco floral motif, available in custom size. The design is determined by the different trimming heights of the silk, which create an elegant three-dimensional effect. This elaborate processing is emphasized by the lustre of the silk that makes this carpet particularly precious. Density: 100 knots/squared inch. The carpet is hand knotted without any child labour.
MADE IN NEPAL.

DIMENSIONS

Due to the pattern of the carpet, for the rectangular shape we suggest a size of 290x390 cm. Other sizes can be ordered only after the approval of the design.

MATERIALS

100% SILK

OTHER COLOURS



OFF WHITE



POWDER BLUE

ECCELISO

Rug with irregular *canneté* effect, available in custom size. The pattern is obtained by using two different techniques, loop pile and cut-pile, with different height. The alternance of glossy silk and matt wool emphasizes this effect. The carpet is hand knotted without any child labour.
MADE IN NEPAL.

DIMENSIONS

Custom size

MATERIALS

50% SILK / 50% WOOL



BEIGE / GREY

GEM

Rug with loops pile border, available in custom size. The loops pile technique is developed with different heights on the vertical borders only, creating a particular dégradé motif. Density: 100 knots/squared inch. The carpet is hand knotted without any child labour. MADE IN NEPAL.

DIMENSIONS

Custom size

MATERIALS

100% SILK

OTHER COLOURS



BLUE SHADOW



MILITARY

GINNY

Rug with interrupted stripes design, available in custom size. This carpet presents the same design of the Rebel rug, but with an interrupted pattern. The interruption of the stripe is created by the loop pile effect in a lower pile height. Density: 100 knots/squared inch. The carpet is hand knotted without any child labour. MADE IN NEPAL.

DIMENSIONS

Custom size

MATERIALS

100% SILK

OTHER COLOURS

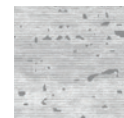

GREY



BEIGE / WATER GREEN



SAND

JAEN

Rug with shaded stone texture, available in custom size. The impressive design evokes a marble slab and recalls the Nabucco wallpaper pattern. The fine shading effect of the different yarns ensures a very detailed pattern. Density: 100 knots/squared inch. The carpet is hand knotted without any child labour. MADE IN NEPAL.

DIMENSIONS

Custom size

MATERIALS

100% SILK

OTHER COLOURS

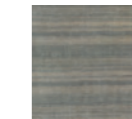

CREAM

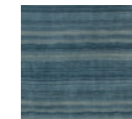

JADE

MASON

Rug with Art Déco inspired labyrinth design, available in custom size. The décor is created with relief and carving techniques, as well as with different quality yarns. The wool yarns create the ground where the silk yarns arise at times over the surface, to highlight the design. Density: 100 knots/squared inch. The carpet is hand knotted without any child labour. MADE IN NEPAL.

DIMENSIONS

Custom size

MATERIALS

65% SILK / 35% WOOL

OTHER COLOURS



OFF WHITE



PEARL



CHAMPAGNE

MAX

Rug with large shaded stripes, available in custom size. The fading stripes are created thanks to the different colour tones and with shiny and matt effect of the wool and silk yarns. Density: 100 knots/squared inch. The carpet is hand knotted without any child labour.
MADE IN NEPAL.

DIMENSIONS

Custom size

MATERIALS

50% SILK / 50% WOOL

OTHER COLOURS



PEARL



SAND

MILES

Rug with wavy design, available in custom size. The three-dimensional effect to the full width design comes from the relief technique and from the shading of the stripe lines. Density: 100 knots/squared inch. The carpet is hand knotted without any child labour.
MADE IN NEPAL.

DIMENSIONS

Due to the pattern of the carpet, we suggest a size of 300x400 or 400x400 cm. Other sizes can be ordered after the approval of the design.

MATERIALS

100% SILK



TAUPE / CHAMPAGNE



PEARL / PLATINUM

MORGAN

Rug with striped chevron design, available in custom size. Wavy chevron stripes create an intertwined macro effect on this silk carpet. The design is created with carving techniques as well as with the tone-on-tone colouring. Due to the modularity of the design - based on a 150x150 cm square - the carpet is presented in special sizes (see below for details). Density: 100 knots/squared inch. The carpet is hand knotted without any child labour.
MADE IN NEPAL.

DIMENSIONS

The Morgan range can be ordered as follows:
300x450 cm - Inch 118.1x177.2 (Only option available for showroom display)
450x450 cm - Inch 177.2x177.2
450x600 cm - Inch 177.2x 236.2

MATERIALS

100% SILK

NOIR

Gradient coloured stripes fading from white to a pitch black background give a dramatic twist to this precious rug in silk. The silk enhances the graphic perspective design with strong colour contrast, while the carving makes the precise lines to stand out. Available in custom size. Density: 100 knots/squared inch. The carpet is hand knotted without any child labour.
MADE IN NEPAL.

DIMENSIONS

Due to the pattern of the carpet, we suggest a size of 300x400cm. In case of other sizes, the design will be scaled to match the dimensions requested.

MATERIALS

100% SILK



BLACK / WHITE

NOONA

The wool background highlights the horizontal silk stripes in relief. This classic Armani/Casa pattern, in refined hues, offers a sophisticated background for the interior décor. Available in custom size. Density: 100 knots/squared inch. The carpet is hand knotted without any child labour. MADE IN NEPAL.

DIMENSIONS

Custom size

MATERIALS

50% SILK / 50% WOOL

OTHER COLOURS



POWDER BLUE / GREY



BLACK / ANTHRACITE

NOVA

Rug with an irregular grid design highlighted with relief. The background is created with the loop technique in wool, giving a lively texture and contrast to the design on the cut silk surface. Available in custom size. Density: 100 knots/squared inch. The carpet is hand knotted without any child labour. MADE IN NEPAL.

DIMENSIONS

Due to the pattern of the carpet, we suggest a size of 300x400cm or 400x400cm. In case of other sizes, the design will be scaled to match the dimensions requested.

MATERIALS

95% SILK / 5% WOOL

OTHER COLOURS



MILITARY / BEIGE



SAND



ICE

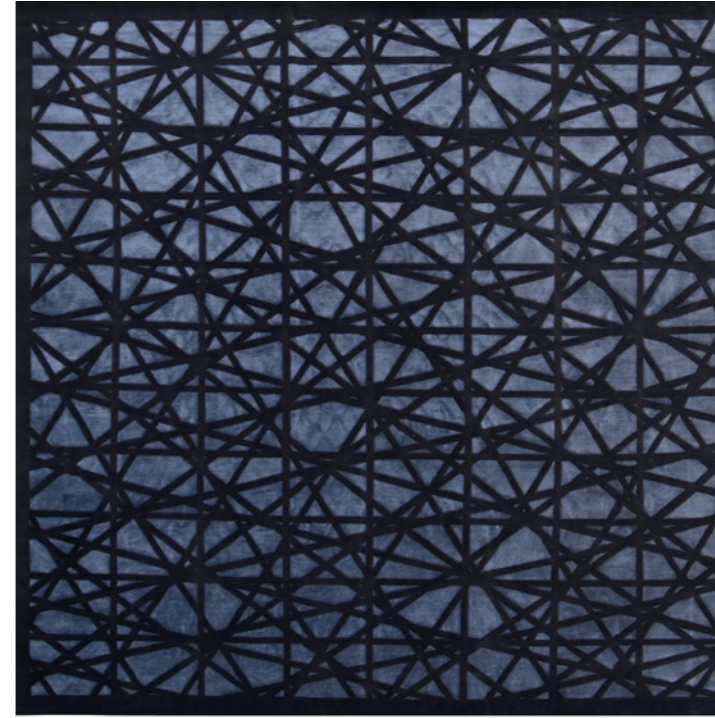

NIGHT BLUE



PETROLEUM / ICE

OBI

The design of this rug takes inspiration from the Asian culture, from ribbons and knots of the *obi*, the belts of Japanese kimonos. Those belts were traditionally made with pure silk, like the precious ground of the carpet crossed by wool lines. A frame running on the edge of the rug completes the three-dimensional grid. Available in custom size; on smaller rugs, the design will be resized to better fit the surface. Density: 100 knots/squared inch. The carpet is hand-knotted without any child labour. MADE IN NEPAL.

DIMENSIONS

Custom size

MATERIALS

50% SILK / 50% WOOL

OTHER COLOURS



ICE



POWDER

ORCHESTRA

This rug shows a vintage design, obtained with a production process which is particularly long and difficult. Density: 100 knots/squared inch. Available in custom size. The carpet is hand-knotted without any child labour. MADE IN NEPAL.

DIMENSIONS

Custom size

MATERIALS

100% VISCOSE

OTHER COLOURS



SAND

ORIENTE

A design inspired by the Far East, featuring trees and hills shading into clouds to create an “infinite” perspective. The stunning level of detail is achieved by using a complex production process, which requires frequent changes of fibers in different colours while hand knotting; the result is a carpet showing thousands of shades and hues, recalling a sort of watercolour effect. Available in custom size. Density: 100 knots/squared inch. The carpet is hand-knotted without any child labour. MADE IN NEPAL.

DIMENSIONS

Custom size

MATERIALS

100% SILK

OTHER COLOURS



ICE



SAND

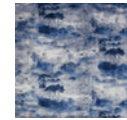

NIGHT BLUE



PETROLEUM

PABLO

Pablo shows a design featuring two frames running on all borders of the carpet. The outer one, like the central part, is made with cut pile technique on silk and features a watercolour effect to make this frame more vivid; the inner one is thin and is obtained through a loop technique on wool. The alternance of different three-dimensional effects and colour shades increases the contrast between all parts. Density: 100 knots/squared inch. The carpet is hand-knotted without any child labour. MADE IN INDIA.

DIMENSIONS

Custom size

MATERIALS

80% SILK / 20% WOOL



GOLD / IVORY

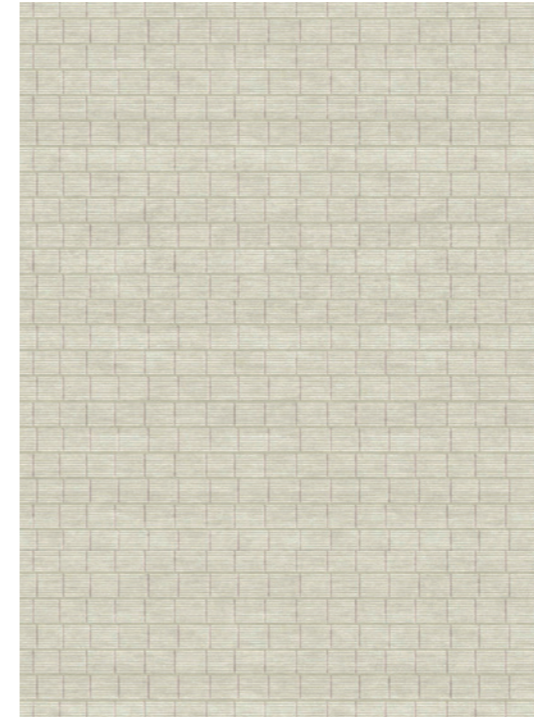

PEARL

PARADE

Parade is marked by plain horizontal lines. The wool background with silk lines in relief creates a three-dimensional *canneté*-inspired texture. The vertical lines cross the horizontal ones and create the illusions of irregular *canneté* tiles: the final design is a sort of irregular checkerboard, which echoes another iconic Armani motif. The entire rug is made with the cut technique; the three-dimensional effect is made more evident by the pile of the *canneté* lines, which is longer than the others. Density: 100 knots/squared inch. The carpet is hand-knotted without any child labour. MADE IN INDIA.

DIMENSIONS

Custom size

MATERIALS

60% SILK / 40% WOOL

OTHER COLOURS

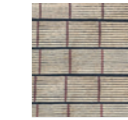

BLUE / LILAC / SAND

PURPLE

The design of the *Purple* rug is obtained by playing with the round GA logo, deconstructed in order to create a repeating geometric module. A thin frame runs on all borders of the carpet, made with loop technique as the background; the repeating design, instead, is made with the cut pile technique, so that it remains more shiny than the other parts and hence more visible even on a tone-on-tone colour palette. Density: 100 knots/squared inch. The carpet is hand-knotted without any child labour. MADE IN NEPAL.

DIMENSIONS

Custom size

MATERIALS

100% SILK



ICE

PHILOSOPHER

The design of the *Philosopher* rug takes inspiration from the intertwined design of some fabrics within our collection. The background is in silver silk with both cut pile and loop technique; the texture in relief is given by horizontal lines in Dove Grey and vertical ones in Azure. The three-dimensional effect is particularly evident on this carpet. Density: 100 knots/squared inch. The carpet is hand-knotted without any child labour. MADE IN INDIA.

DIMENSIONS

Custom size

MATERIALS

100% SILK

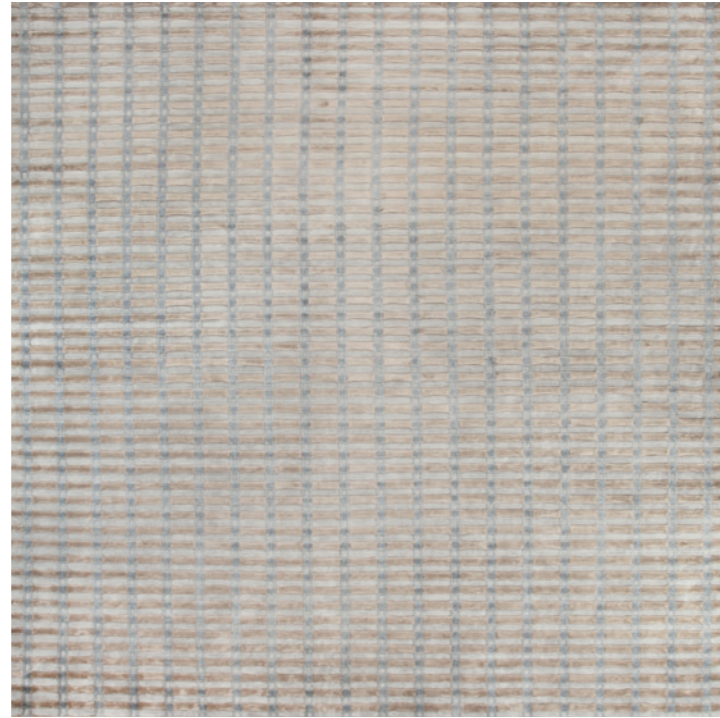

SILVER / DOVE GREY / AZURE



TAUPE / BEIGE

REAME

Rug with palm leaf motif, available in custom size. Density: 100 knots/squared inch. The carpet is hand knotted without any child labour. MADE IN NEPAL.

DIMENSIONS

Due to the pattern of the carpet, we suggest a size of 400x400 cm. Other sizes can be ordered after the approval of the design.

MATERIALS

50% SILK / 50% WOOL

OTHER COLOURS



PEARL



PETROLEUM

REBEL

Rug with striped design, available in custom size. Density: 100 knots/squared inch. The carpet is hand knotted without any child labour. MADE IN NEPAL.

DIMENSIONS

Custom size

MATERIALS

50% SILK / 50% NETTLE (cream / beige option)
100% SILK (ivory / black option)

OTHER COLOURS



IVORY / BLACK



MILITARY



CREAM / BEIGE



GREY

TUTANKHAMON

Rug with alligator skin design, available in custom size. Density: 100 knots/squared inch. The carpet is hand knotted without any child labour. MADE IN NEPAL.

DIMENSIONS

Custom size

MATERIALS

90% SILK / 10% WOOL

OTHER COLOURS



OFF WHITE

TANYA

Tanya is a hand-knotted rug in silk presenting an exceptional density. The edges of this rug are completed by a hand-sewn blanket stitch borders, made in Italy with tone-on-tone wool fibers. Density: 150 knots/squared inch. The carpet is hand knotted without any child labour. MADE IN INDIA.

DIMENSIONS

Custom size

MATERIALS

100% SILK

OTHER COLOURS



POWDER BLUE



BRONZE

TATE

Tate is a hand-knotted rug presenting a geometric design based on the repetition of a fixed module: in fact, Tate can be ordered only in sizes multiple of the rectangle measuring 150 x 133,3 cm. The only exception is the size 300 x 300 cm, where the module will be a square measuring 150 cm per side. Each module features a ground in wool with loop technique - inspired by Japanese tatami - with profiles in silk. Density: 100 knots/squared inch. The carpet is hand knotted without any child labour. MADE IN NEPAL.

DIMENSIONS

By repetition of the module

MATERIALS

87% WOOL / 13% SILK

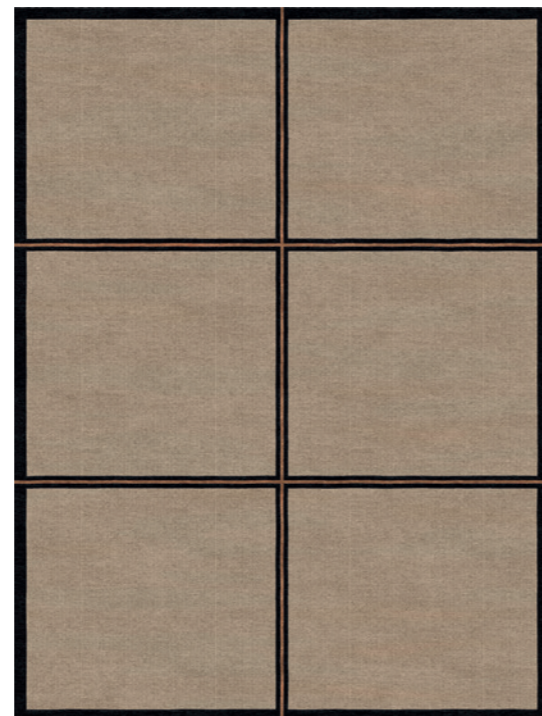

BLACK / BRONZE

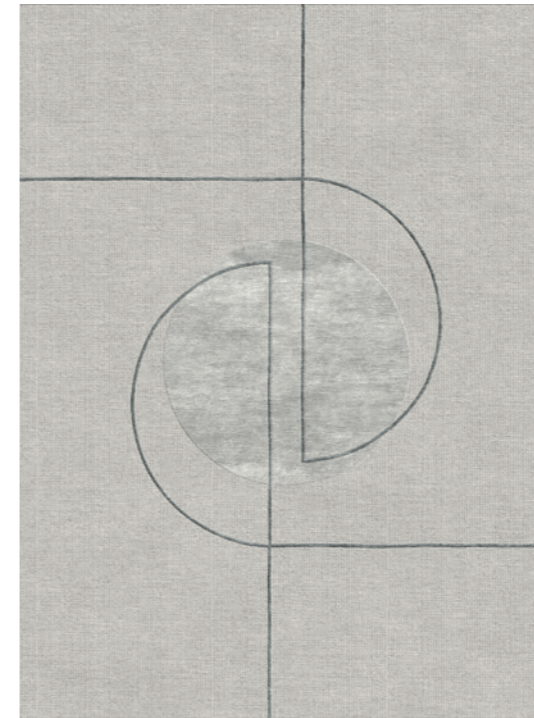

OFF WHITE / PEARL

TAYLOR

Taylor is a hand-knotted rug featuring a ground in wool - made with a loop technique - and a design in silk (relief on the semicircles, carving on the lines). The sleek geometries created by pure lines and shapes were born from the deconstruction of a stylized GA logo, simplified to obtain an extreme minimalism. In case of particularly small or wide sizes, the design will be scaled accordingly. Density: 100 knots/squared inch. The carpet is hand knotted without any child labour. MADE IN NEPAL.

DIMENSIONS

Custom size

MATERIALS

86% WOOL / 14% SILK

TRAVIS

Travis is a hand-knotted rug in silk. The design, featuring a dreamy landscape enveloped in the mist, is inspired by the Giorgio Armani Fall Winter 2021-22, where it was used as backdrop for the ADV campaign. The same design is present on the Sachiko plaid from the Armani/Casa permanent collection. In case of particularly small or wide sizes, the design will be scaled accordingly. Density: 100 knots/squared inch. The carpet is hand knotted without any child labour. MADE IN NEPAL.

DIMENSIONS

Custom size

MATERIALS

100% SILK

OTHER COLOURS



BLUE



PLATINUM

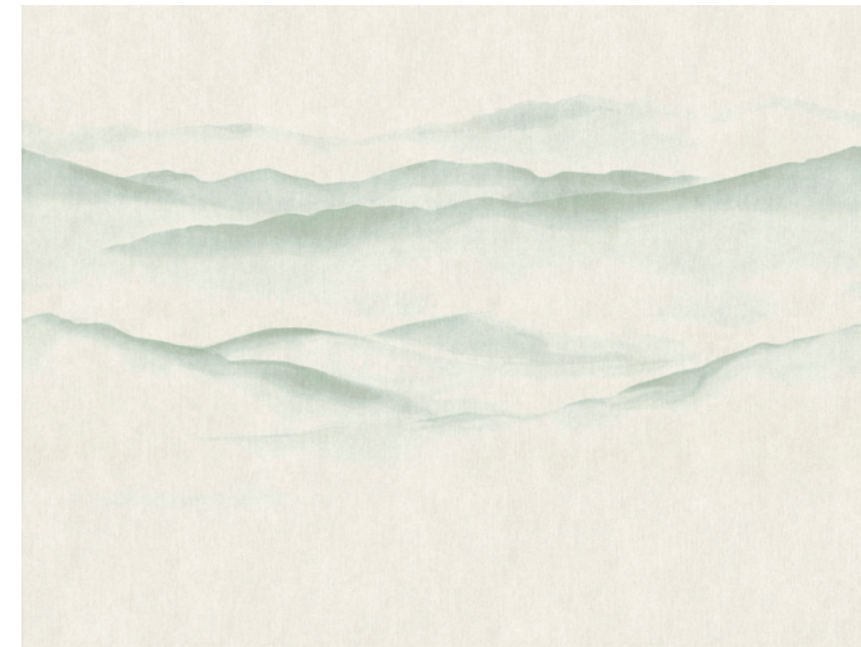

SAGE GREEN / GOLD

RIDGE

Ridge is a mat characterized by vertical lines in relief, which create the illusion of a typical motif of the Armani style: *canneté*. The rows are interrupted by contrasting colour blocks of different sizes. *Ridge* features a tone-on-tone border running on the upper and the lower side. Available in two colours.
MADE IN INDIA.

DIMENSIONS

Custom size.

MATERIALS

85% WOOL FROM NEW ZEALAND / 15% COTTON.
BINDING: 100% LINEN

OTHER COLOURS

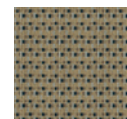

SAND / STEEL / PETROLEUM

RASHOMON

Rashomon features two iconic elements of the Armani aesthetics: the checkerboard motif and *canneté*. The mat is made by alternating squared modules with a different orientation - vertical or horizontal - of three-dimensional lines, developed using contrasting colours. The result is a mat with a maxi-woven effect. Available in two colours.
MADE IN INDIA.

DIMENSIONS

Custom size.

MATERIALS

80% WOOL FROM NEW ZEALAND / 20% COTTON

OTHER COLOURS



GREY / ANTHRACITE



ICE / GREY



NATURAL

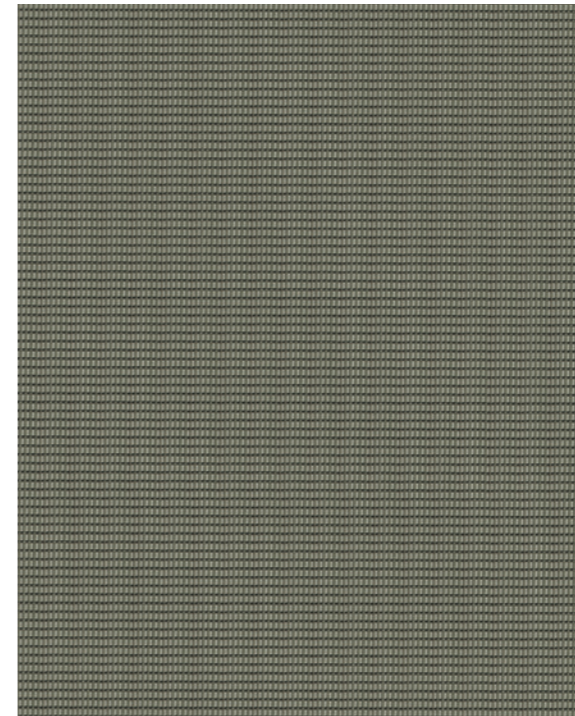

OLIVE GREEN

ROY

The three-dimensional texture made by thick lines of the mat creates the effect of a tatami, the typical Japanese carpet, depicted in macro scale. *Roy* has a tone-on-tone edge and is available in four different colours.
MADE IN INDIA.

DIMENSIONS

Custom size.

MATERIALS

50% JUTE / 40% VISCOSE / 10% WOOL

OTHER COLOURS



AZURE / BEIGE

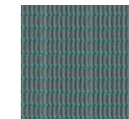

PETROLEUM / AZURE

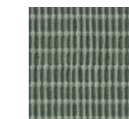

CEDAR /
VERONESE GREEN

TOM

Tom is a mat for outdoor. The design replicates the one of the Roy mat for indoor environments, part of the Armani/Casa permanent collection and showing a texture inspired by Japanese tatami. To obtain a version suitable for open air spaces, the composition features 100% recycled PET, which - together with the use of certified ecological dies - guarantees the sustainability of the product. Tom is 100% water resistant. MADE IN INDIA.

DIMENSIONS

Custom size.

MATERIALS

100% PET

OTHER COLOURS

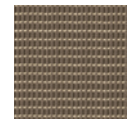

BRONZE

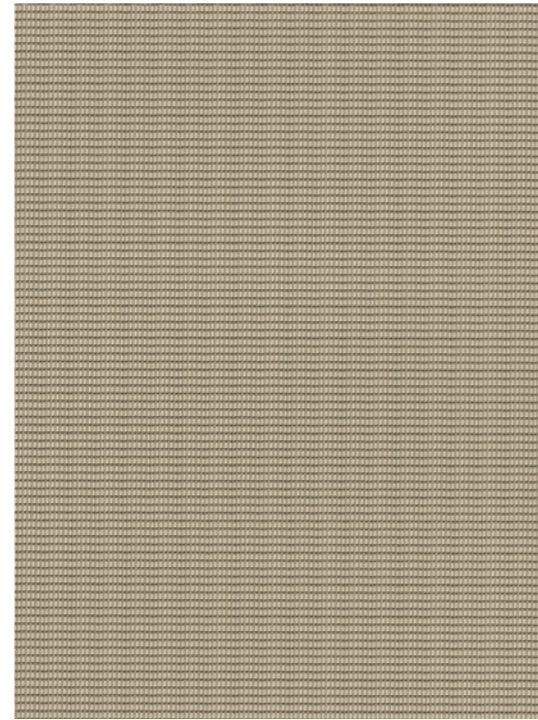

SAND

TOQUINHO

Toquinho is a mat for outdoor. The design is marked by a strong three-dimensionality since the fibers used for the weaving create a macro intertwined motif. Toquinho is 100% water resistant. MADE IN INDIA.

DIMENSIONS

Custom size.

MATERIALS

100% OUTDOOR PROPYLENE

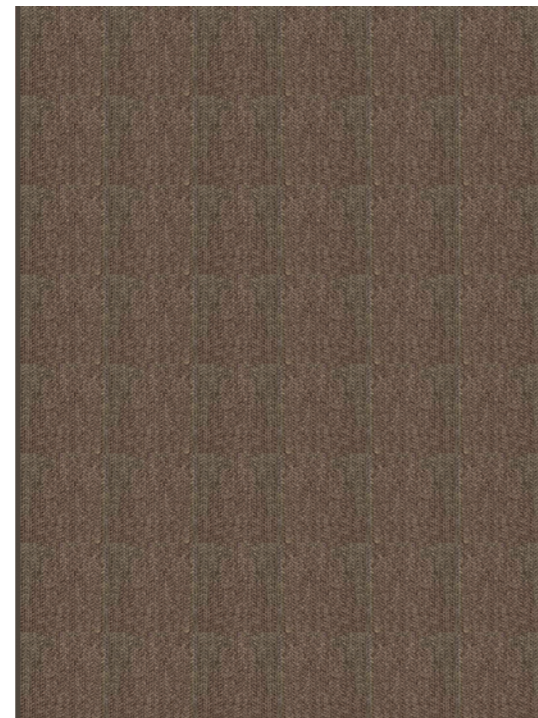

BRONZE

RUGS

CORPORATE SOCIAL RESPONSIBILITY

As part of the Armani Group, Armani/Casa is particularly sensitive to social aspects. The brand totally fulfills the Nepalese laws which grant the respect of the rights of knotters in terms of working hours per day, Monday-to-Friday shifts, proper wages and age of the employees.

COLOURS

The colours printed in this catalogue give only an idea of the actual hue of the final product. We suggest checking the updated samples available in all our stores. Always keep in mind that slight colour variations may occur from dye lot to dye lot.

DESIGN

To determine the direction in which the design will be developed on rectangular carpets, please refer to the related technical sheets or pictures in this catalogue. When ordering a rug, the first size communicated must correspond to the horizontal dimension (as photographed) of the carpet itself.

SIZES

Due to the handmade nature of our products, a size variation of up to 5% in relation to the ordered size may occur. Rugs exceeding a total of 20 square meters have dedicated prices that will be calculated upon request.

MATS

WEAVING

Mats are thin rugs made by using a pit loom. As the name suggests, this type of loom fits in a pit where artisans weave the rug through the aid of special pedals. In this technique, the mat is weaved parallel to the ground, which helps making those rugs less dense and stiff. While the warp is kept in tension thanks to two rows of pegs, the wefts are inserted by hand to create the design. A high level of craftsmanship is required to obtain those products, marked by the absence of pile and backing.

SUSTAINABILITY

Armani/Casa mats are made by using yarns coloured through a 100% ecological dyeing process with azo-free hues. They do not contain any harmful substance for the environment, pets or human beings: our suppliers operate in compliance to REACH SVHC regulations.



MATERIALS



The Armani/Casa collection includes many finishes developed exclusively for the brand, born from the reinterpretation of traditional techniques as well as from the infinite possibilities offered by modern technologies.

The range of materials comprises stones, woods, metals, leathers and many handmade precious finishes which require skillful artisans to be completed.

MAPLE

Our maple features veneer coming from plants belonging to the *Acer* genus. The typical narrow streaks of this wood are emphasized by the finish: a glossy surface enriches the black option featured in our collection. Area of origin: Europe.

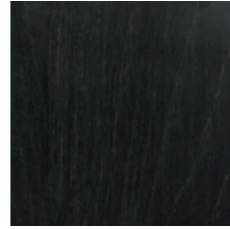

BLACK MAPLE



CANALETTO WALNUT

OAK

Oak (*Quercus petraea*) is probably the most popular essence for furniture. Both oak versions in our collection are matt and covered by a layer of transparent protective paint. Area of origin: Europe



BRUSHED BROWN OAK

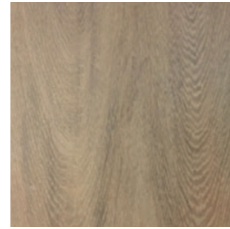

BRUSHED GREIGE OAK

ASHWOOD

Ashwood (*Fraxinus spp.*) is marked by clearly visible streaks, which create an exceptional visual impact. Ashwood plays around strong three-dimensional effects: a heavy brushing phase gives the surface a typical irregular appearance that highlights the natural veins of the material. The wood is finally covered with a protective layer of transparent matt dye. Area of origin: Europe



BRUSHED BLACK
ASHWOOD

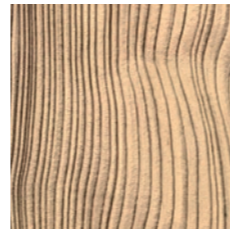

BRUSHED HONEY
ASHWOOD

WALNUT

Walnut is present within our collection in its American version (*Juglans nigra*): the name "canaletto" comes from Italian and it is due to the tiny canals visible into the wooden texture, which transport sap inside the plant. Area of origin: North America.

CLASSIC AND EXOTIC ESSENCES

The Armani/Casa collection is rich in many woods varying in colour, texture and origin.

Olive - an uncommon essence in home environments - underlines the deep bond of our brand to the Mediterranean. The collection also includes exotic woods such as shiny rosewood from South America (*Machaerium scleroxylon*).

All essences do not need any CITES documentation, since they do not come from endangered species: this is an ethic choice that Armani/Casa pursues in order to fulfill the Corporate Social Responsibility of the Armani Group.



GREIGE TULIPIER



OLIVE



SHINY SANTOS
ROSEWOOD



TEAK



WEAVED TEXTURED TEAK

TEAK

Teak is a naturally weather resistant wood suitable for outdoor environments. Weaved Textured Teak is marked by a three-dimensional carving reminding the weave of fabrics. Area of origin: Asia.

METALS

Always aiming to create the best chromatic harmony, Armani/Casa offers several colours of metals to perfectly match all other finishes in collection. Golden tones, in particular, are typical within the Armani/Casa palette. Each metal is characterized by a different treatment of the surface (satin or glossy) and shows a modern or a vintage look. Satin Light Brass is entirely hand polished to obtain its typical appearance.



BRONZED BRASS



GLOSSY NATURAL BRASS



SATIN LIGHT BRASS



SATIN NATURAL BRASS

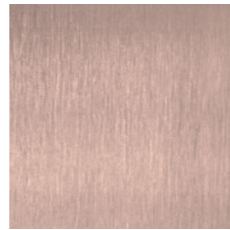

SATIN ROSE BRASS



BLACK PAINTED STEEL

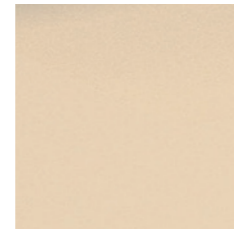

CHAMPAGNE METAL

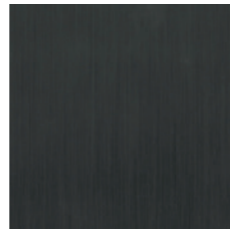

SATIN BLACK NICKEL

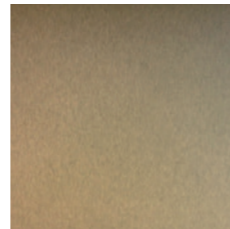

SMOKED GOLD

SPECIAL METALS

The use of metal - and other exclusive finishes imitating this material - is a signature element of Armani/Casa. Onyx-Textured Metal combines metal with another element typical of our brand, onyx, Giorgio Armani's favorite stone because of its tone-on-tone striped design. An advanced ink printing technology is used to replicate the onyx pattern: in this way, the design "penetrates" the metallic surface so that it can become more vivid and resistant.



ONYX-TEXTURED METAL

STONES

Stones are a very important element in the Armani aesthetic philosophy, since they are the ultimate expression of Nature's beauty and eternity. Armani/Casa uses the most astonishing stones in the world for its collections, selecting every slab individually to find the best possible hue and design. Examples of this research are Taj Mahal Quartzite from Brazil, Grey Marble from Colombia, Selenite from Morocco and Sodalite from Bolivia.

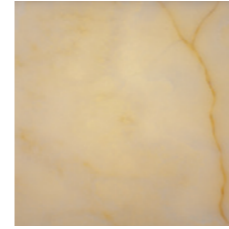

ONYX

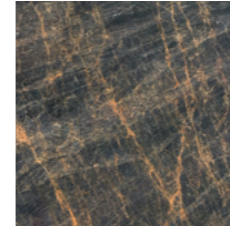

GREY COLOMBIAN MARBLE



SELENITE

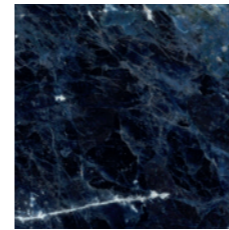

SODALITE



TAJ MAHAL QUARTZITE

SHELLS

Shells are the perfect example of how Armani/Casa can transform the beauty of Nature into astonishing finishes. Marine Pen Shell is made in Indonesia, where skillful artisans treat pen shells to obtain an alternating black/grey striped design. Shell Mosaic features a rich texture given by the pearlescent surface of mother-of-pearl tiles, assembled together to create a mosaic playing with squared and rectangular shapes.



MARINE PEN SHELL



SHELL MOSAIC

LINEN

The Armani/Casa collection includes decorative finishes inspired by the naturalness of linen.

Kyoto Texture is made with real linen fabric in natural colour featuring dark red lacquered inserts.

Lacquered Red Linen features linen fabric coupled with gold leaf and then painted in red, where a layer of transparent lacquer adds the final shiny touch leaving the textured surface visible.



KYOTO TEXTURE

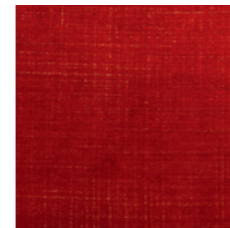

LACQUERED RED LINEN

STRAW MARQUETRY

This finish has become an Armani/Casa signature through the years. The origins of this technique are ancient: first traces of straw marquetry can be found in Far East countries and date back to the Middle Age. Only after the late XVII century this decoration spread in central Europe, especially in France. The process to obtain this finish is handmade and requires several steps in which the skill of the artisan is crucial: from the cutting of rye straws to their flattening, from their glueing to the final polishing, everything must be carefully done to obtain the typical look of this precious material.

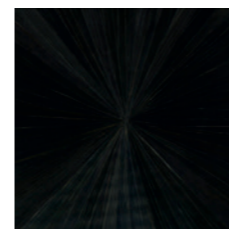

BLACK STRAW MARQUETRY



BRONZE STRAW MARQUETRY

GLASSES

The Armani/Casa collection includes a range of exquisite Murano glass, made following the ancient techniques of Murano glassmaking. The appearance of these creations is marked by streaks and veins in different tones, layered in the thickness of the glass in order to create a sense of major depth and imitating the look of stones. The silky touch of the surface is due to the final polishing phase.

Orsini Glass is a breath-taking finish inspired by the Neoclassic architectural details of Palazzo Orsini, like the water green walls and golden stuccos. This finish is obtained by hand painting the back of a tempered extra-clear glass with a special paint mixing different pastel tones, using a large soft brush. The application of the paint is uneven, hence leaving some areas more transparent than others; the addition of real gold leaf adds a further touch of preciousity and layers of depth. The final passage is a protective painting, in order to fix and protect the finish while making the surface completely smooth.



BLACK GLASS



DOVE GREY MURANO GLASS



ORSINI GLASS

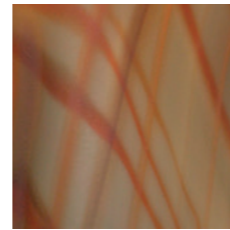

SUNSET MURANO GLASS

NATURAL MATERIALS

Crisscross Natural Straw is obtained using a base panel covered by vertical rye straws, contrasting with the horizontal ones glued to leave the background visible. The alternance of vertical and horizontal stripes affects the way light hits the surface, giving back several tones of gold and brown that change depending on the angle of view. The finish is covered by a layer of matt transparent paint to make the surface smooth and more resistant. Like marquetry, this finish requires many hours to be completed: the straws are carefully glued one by one to create the intricate pattern.

Natural-Black Tatami is a textured material obtained by weaving paper yarns around a core of resistant cotton strings. The tatami-inspired surface is marked by a three-dimensional motif, recalling a *canneté* effect thanks to the two contrasting colours: these features create a strong link to the world of fashion and Japanese culture at the same time.

Hazelnut Midollino, with its woven detailing, features a three-dimensional texture obtained through the traditional artisanal technique of wicker.

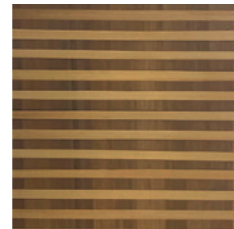

CRISSCROSS NATURAL STRAW

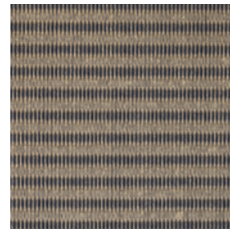

NATURAL-BLACK TATAMI

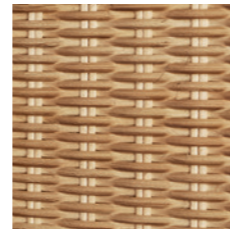

HAZELNUT MIDOLLINO



BLACK DRAFTED STUCCO

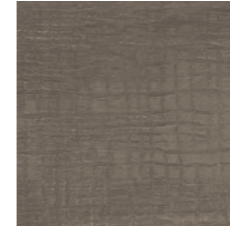

MUD DRAFTED STUCCO

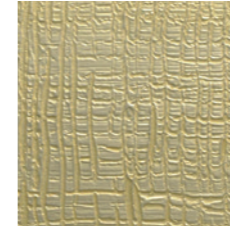

WHITE GOLD DRAFTED STUCCO



WHITE GOLD STRIPED STUCCO

STUCCO

This typical wall decoration technique has been reinterpreted by Armani/Casa with the creation of these precious finishes. The drafted versions, available in four colours, are obtained by creating an irregular grid on wet stucco; once dry, the surface is finished with a protective layer of glossy lacquer.

White Gold Striped Stucco, instead, is the result of the combination of three different elements: a carved wood panel featuring a striped design reminding the *canneté* texture of fabrics, a layer of natural stucco and a final application of silver leaf.

GOLD AND SILVER LEAF

The art of gilding is very ancient: Egyptians used to gild wood and metals, and also Greeks knew a similar technique. The extensive use of gilding spread especially during the Roman Republic period and continued for all the following centuries, becoming a typical decoration for jewelry, statues, picture frames, paper art, small objects, architectural details and luxury furniture. The gilding of Armani/Casa furniture is a completely handmade process, which is carried out thanks to the skill of artisans applying the thin metal sheets (0,2 micron thickness) on wood with the aid of a brush and a wet sponge only.

Gold leaves are made with real 12-karat gold and are available in two tones, from a very pale and delicate white gold to a more vintage tone; silver leaf, is presented in a romantic *rosé* version enriched by a touch of copper.



BRUSHED SILVER LEAF



PATINATED SILVER LEAF



WHITE GOLD LEAF

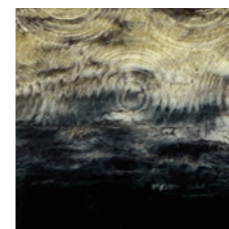

MOONLIGHT DECORATION

DECORATIVE RESINS

Ivory and black, two sides of the same elegance envisaged by Giorgio Armani. The neutral tones of the first blend in the velvety essence of the second, creating a stunning three-dimensional finish for Armani/Casa. Inspired by the delicate brightness of the moon and its reflections on water and clouds, the Moonlight Decoration enchants with its *dégradé* effect, as well as with the uneven appearance: circles, carved in the resin to imitate the concentric ripples created by drops, add movement to the surface resembling water mirroring the night sky.

HANDMADE / HAND PAINTED LACQUERS

These finishes represent the highest level of artisanship and are deeply linked to art.

Caribbean Lacquer is obtained by applying three layers of different colours on the same surface: the paint is later removed in specific areas in order to show the contrasting hues underneath, creating irregular stripes with blurred borders. The whole process is handmade.

Golden Sea Waves Lacquer, instead, presents golden hand painted streaks on a shellac ground, recreating a play of reflections on water half way between the softness of Impressionism and the luster of Art Déco.

Sky Lacquer is entirely hand painted and reinterprets the hues of the *Cloud Studies* that the English painter J. Constable (1776-1837) painted as a tribute to his homeland.



CARRIBEAN
LACQUER

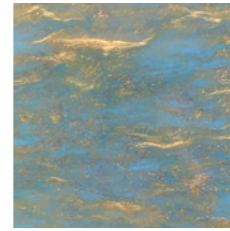

GOLDEN SEA WAVES
LACQUER



SKY
LACQUER



BLUE TUAREG
LIQUID METAL

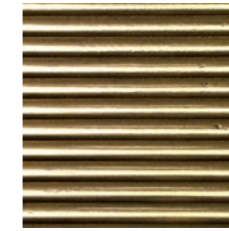

BRASS CARVED
LIQUID METAL



PATINATED
LIQUID METAL



TATAMI
LIQUID METAL

LIQUID METALS

Liquid metals are a new generation of lacquers featuring real metal pigments, which give the finishes a distinctive look: in fact, all these materials present a typical reflectance and a cold touch resembling the one of real metal. Depending on the support – carved, brushed or perfectly even – and the desired hue, it is possible to obtain different effects. On ash, for example, it is possible to appreciate the natural veins of wood below the silver lacquer, while the carved versions create the illusion of vintage metal rods.

A rich tone of blue, marked by a particular visual depth and inspired by the traditional turbans of tuaregs is the main feature of the Blue Tuareg Liquid Metal. A first layer of silver liquid metal is applied on the surface, which is then hand brushed and finally covered with a layer of blue lacquer.

OTHER LACQUERS

Many of the lacquers by Armani/Casa show a distinctive look, given by the texture or the metallic shine of the surface.

Platinum Waves Lacquer presents a design of wavy lines, visually recalling an irregular canneté. The effect is obtained thanks to the most superficial veneer, whose increspated surface adds movement to the whole finish. The final touch is the addition of a platinum lacquer, enriched by a very light rose hue.

Watoji Lacquer is a black lacquer marked by the presence of inlays in Satin Light Brass, whose design is inspired by the traditional Japanese technique of bookbinding.

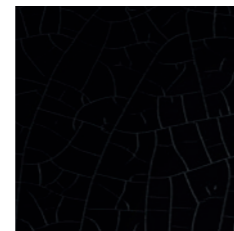

BLACK CRACKLED
LACQUER



JAPAN RED
LACQUER

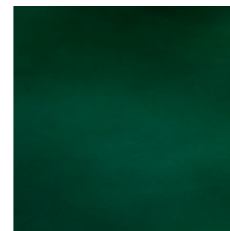

JUNGLE
LACQUER

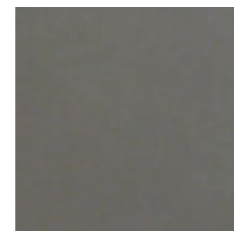

METAL
LACQUER

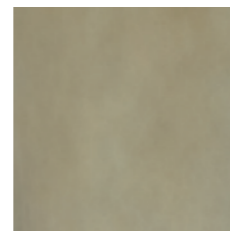

PLATINUM
LACQUER



PLATINUM WAVES
LACQUER

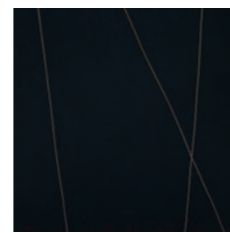

WATOJI
LACQUER

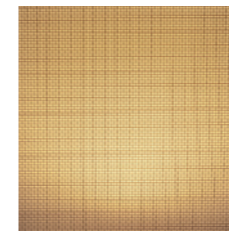

GOLDEN
METHACRYLATE

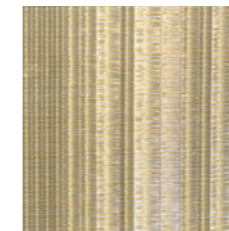

GOLDEN CANNETÉ
METHACRYLATE



TRANSPARENT
METHACRYLATE

METHACRYLATE

Methacrylate is a high-performing material with unique characteristics: more transparent than glass and very resistant, it can be used to obtain particular effects. The Armani/Casa collection features different versions of this material coupled with metal mesh, where the final colour depends both on the hue of the metal itself and the colour of methacrylate layers enclosing the mesh.

LEATHERS (CUOIO)

'Cuoio' is the thick leather of the Italian tradition, typical of central regions such as Tuscany. Due to its thickness, this cow leather is available only on some products like some chairs and desks. The surface of cuoio is quite smooth and homogeneous.



BLACK
LEATHER (CUOIO)



COGNAC
LEATHER (CUOIO)



CORTECCIA BROWN
LEATHER (CUOIO)



DARK BLUE
LEATHER (CUOIO)

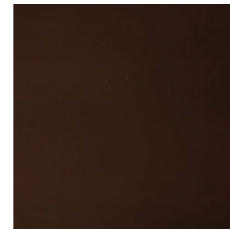

DARK BROWN
LEATHER (CUOIO)



DARK GREEN
LEATHER (CUOIO)

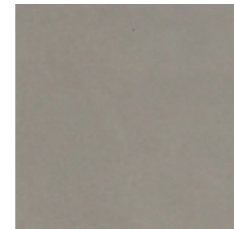

DOVE GREY
LEATHER (CUOIO)

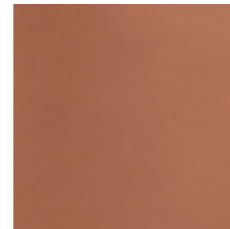

NATURAL
LEATHER (CUOIO)



RED
LEATHER (CUOIO)

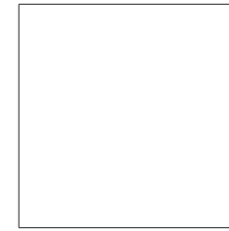

ICE
SOFT TOUCH LEATHER

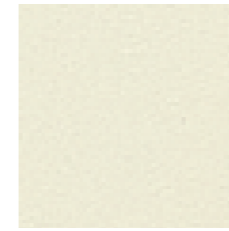

IVORY
SOFT TOUCH LEATHER



SAND
SOFT TOUCH LEATHER

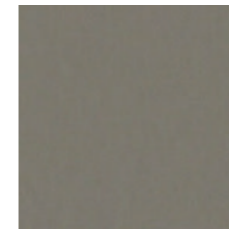

LIGHT BROWN
SOFT TOUCH LEATHER

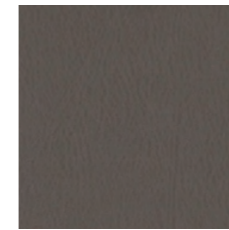

DOVE
SOFT TOUCH LEATHER

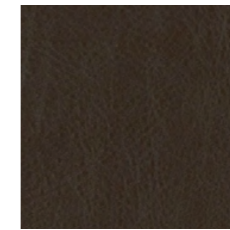

BROWN
SOFT TOUCH LEATHER

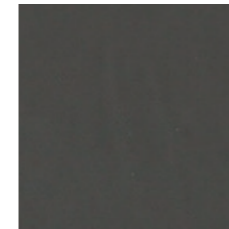

GREEN
SOFT TOUCH LEATHER

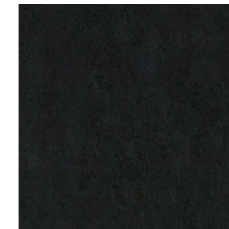

BLACK
SOFT TOUCH LEATHER

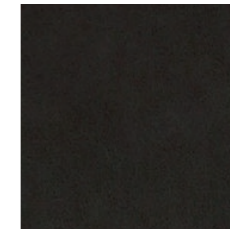

CHARCOAL
SOFT TOUCH LEATHER

SOFT TOUCH LEATHERS

Soft Touch Leathers are tumbled cow leathers, showing a distinctive texture. Available in neutral colours, this kind of leather is suitable for upholstered products. Area of origin: Italy.

THIN LEATHERS

Thin Leathers present a reduced thickness compared to Soft Touch Leathers. They are treated cow leathers featuring a smooth surface, where irregular streaks can be visible: this distinctive feature is typical of the natural raw material and highlights its quality. Thin Leathers are available on a selection of products only. Area of origin: Italy.



NATURAL
THIN LEATHER



BLACK
THIN LEATHER



BLUE
THIN LEATHER



ORANGE
THIN LEATHER



RED
THIN LEATHER



DARK GREEN
THIN LEATHER



COGNAC
THIN LEATHER

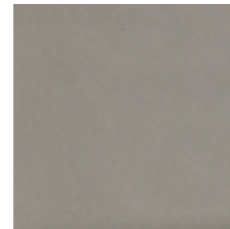

DOVE GREY
THIN LEATHER



WATER GREEN
THIN LEATHER

SHAGREEN-INSPIRED LEATHERS

Jade Shagreen textured leather is crafted through a printing technique followed by hand-brushing, which lightens the colour in relief. Colour and shade can vary from one leather to another.



JADE SHAGREEN
TEXTURED LEATHER



BEIGE VINTAGE
LEATHER



BROWN VINTAGE
LEATHER

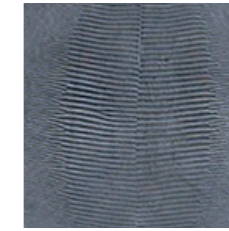

GREY LIZARD EFFECT
LEATHER



JAPAN RED
SOFT TOUCH LEATHER

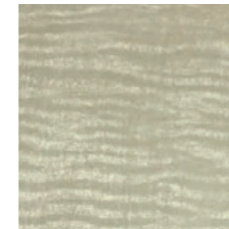

TECHNICAL CHINCHILLA
FABRIC



TECHNICAL PEARL GOLD
FABRIC



TECHNICAL SHAGREEN
FABRIC

OTHER LEATHERS

Some leathers are developed as exclusive materials for specific products. Vintage Beige and Vintage Brown Leather are respectively available on the Paul and Pascal ranges only, and both are marked by irregularities on the surface due to the preciousity of the material.

TECHNICAL FABRICS

Technical fabrics by Armani/Casa are developed on microfiber, which makes them soft and pliable. These materials are stronger than leather on a strength-to-weight ratio but, similarly to leather, their surface features invisible micro pores that can dissipate heat and humidity. Differently from usual fabrics of this kind, they do not contain any PVC: for this reason, they do not release any harmful compounds, thus being safe for use in any environment. Those fabrics are also very resistant to abrasion and provide excellent durability; they even passed the flame retardant test (FR) without any additional treatment.

Depending on the desired effect, these fabrics can undergo different processes to obtain a specific look: Technical Shagreen Fabric, for example, has a custom printed multi-coloured pattern created by a tri-axial matrix, conceived to remind the appearance of the precious rawhide typical of the Armani taste. The other versions of technical fabric reproduce the typical streaks on the fur of chinchilla (Technical Chinchilla Fabric) or a warm-toned leather with pearlescent reflections (Technical Pearl Gold Fabric).

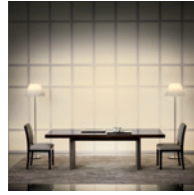

Page 2

TROCADERO Dining table
045513 CH552 C2220

ARIANNA Chairs without armrests
051212 LN00C ER200

PAMELA Floor lamps
050395 UP037 C0052 (Base)
050396 CA236 C0010 (Lampshade)

ORIENTE Rug
050189 CA213 C0050



Pages 16/17

MELROSE Coffee tables
049327 CH545 C0763
049328 CH545 C0763

TROCADERO Dining table
045513 CH552 C2220

ARIANNA Chairs without armrests
051212 LN00C ER200

ORIENTE Rug
050189 CA213 C0050



Pages 114/115

THELMA Outdoor chairs
050780 CT00B TO004

THOMAS Outdoor dining table
050779 CA361 C3555

PICNIC Lanterns
050390 UP050 C1255
050391 UP050 C1255



Pages 134/135

TRILLY Lantern
050791 UP037 C0052
ANTHEA Table lamp
051210 UP066 C6210

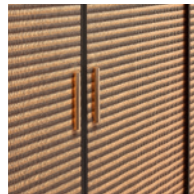

Pages 6/7

ROYAL Bar Cabinet in Limited Edition
045609 CH999 C3810

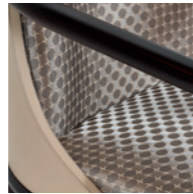

Pages 18/19

AMBRA Chair with armrests
051992 CT00C ER190

ESAGONO Small tables/stools
047788 CA779 C1340

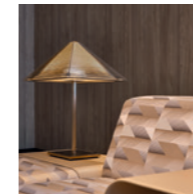

Pages 130/131

LOGO Table lamp
051049 UP059 00151

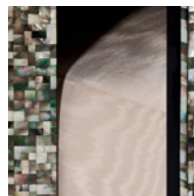

Page 8

ANTOINETTE Coiffeuse in Limited Edition
045609 CH999 C3810

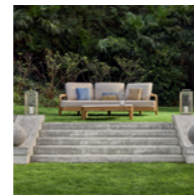

Pages 110/111

TERENCE Outdoor sofa
050773 CA361 C3555 (Structure)
051089 CT00B TO014 (Cushions)

TURNER Outdoor coffee table
050776 CA967 C3555

PICNIC Lanterns
050390 UP050 C1255
050391 UP050 C1255

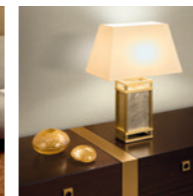
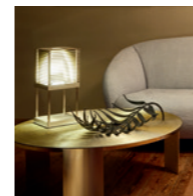

Pages 132/133

MIYA Table lamp
049346 UP015 C0356

RENOIR Sofa
050581 CT00x

MELROSE Coffee table
049327 CA417 C0461

TRILLY Lantern
050791 UP037 C0052

DONNA Table lamp
049080 UP013 C0461 (Base)
049082 CA236 C0010 (Lampshade)

DAMOCLE Chest of drawers
048114 CA336 C0053

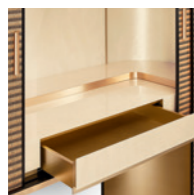

Page 10

ROYAL Bar Cabinet in Limited Edition
045609 CH999 C3810



Pages 14/15

VISO Sofa and footrest
051226 CT00C TX107
051227 CT00C TX107

JOLANDA Floor lamp
050027 UP008 C0454

MASON Rug
049126 CA496C7210

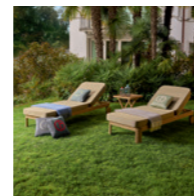

Pages 112/113

TERRY Outdoor small tables
050781 CA361 C3555 (Left)
050777 CA361 C3555 (Right)

TIMOTHY Outdoor Sunbeds
050778 CA361 C3555 (Structure)
051093 CT00x (Cushions)



Pages 166/167

PARADE Rug
CH088 C0640

Pages 168/169
CROQUIS Rug
CA213

RANGE	CATEGORY	PAGE
ALABASTER	Table lamp	155
ALADINO	Floor lamp	136
ALBER	Sofa	26
ALICE	Floor lamp	142
AMBRA	Chair with armrests	40
AMEDEO	Bed	78
ANTHEA	Table lamp	152
ANTOINETTE	Coiffeuse in Limited Edition	9
ANTOINETTE	Coiffeuse	102
ARIANNA	Chair without armrests	44
ARMSTRONG	Rug	170
BALOON	Armchair and footrest	35
BAR	Tall stool	49
BAX	Rug	170
BLOOM	Table lamp	148
BOCCHERINI	Small table	57
BORROMINI	Chaise-longue	32
BURT	Rug	171
CADRE	Rug	171
CAMILLA	Desk	88
CANALETTO	Modular system	20
CASTILLA	Chest of drawers	99
CHAPLIN	Rug	172
CHERIE	Table lamp	146
CIMAROSA	Bedside table	76
CIRCLE	Bar cabinet	97
CLASSIC	Tub chair	42
CLUB	Bar cabinet	96

RANGE	CATEGORY	PAGE
CRONOS	Rug	172
CROQUIS	Rug	173
DALIA	Chair without armrests	47
DAMASIO	Bedside table	75
DANDY	Bed	79
DANZICA	Coffee table	65
DAVID	Bedside table	74
DAVID	Chest of drawers	98
DIOGENE	Table lamp	155
DIVA	Mirror	105
DONNA	Table lamp	148
DORY	Table lamp	149
DUSTIN	Director's chair	43
ECCELSO	Rug	173
EMME	Floor lamp	140
ENYA	Consoles	67
ESAGONO	Small table/stool	63
ESSEX	Armchair	34
EUCLIDE	Desk	88
EVANS	Console	69
GALASSIA	Set of small tables	60
GARCIA	Mattress	87
GARDENIA	Bench	37
GARLAND	Mattress	87
GEM	Rug	174
GILDA	Table lamp	147
GINNY	Rug	174
GIÒ	Bedside table	76

RANGE	CATEGORY	PAGE
GIOTTO	Chair without armrests	46
GLAM	Stool	38
GLAM	Coiffeuse	103
HOPE	Wall light	160
HYADES	Table lamp	154
JAEN	Rug	175
JOLANDA	Floor lamp	136
JOLANDA	Table lamp	154
JOLIE	Desk	90
JYLIA	Chair with armrests	42
LAWRENCE	Footrests	39
LEA	Chair with armrests	41
LINK	Small table	62
LOGO	Table lamp	144
LOGO (Lamellar lampshade)	Table lamp	145
LOGO MINI	Table lamp	144
MASON	Rug	175
MATRIX	Set of consoles	70
MAX	Rug	176
MELROSE	Dining table and coffee tables	56
MENEO	Bedside table	75
MILES	Rug	176
MIRÒ	Multifunctional cabinet	101
MIYA	Floor lamp	138
MIYA	Table lamp and lantern	156
MORFEO	Bed	84
MORGAN	Rug	177
NATHAN	Rectangular dining table	53

RANGE	CATEGORY	PAGE
NELLY	Lantern	158
NEMA	Floor lamp	139
NEMO	Rack	106
NEXT	Floor lamp	143
NEXT	Table lamp	153
NIGHT	Floor lamp	143
NIGHT	Table lamp	152
NOIR	Rug	177
NOONA	Rug	178
NORBERT	Rack	106
NORIGAMI	Coffee table	64
NORIKO	Table lamp	153
NOVA	Rug	178
OBI	Rug	179
OLIMPIA	Bookcase	92
OLIVIA	Desk	90
OMAGE	Chair without armrests	45
OMBRA	Screen	104
ONDA	Chaise-longue	32
OPEN	Modular system	22
ORCHESTRA	Rug	179
ORESTE	Small table	61
ORIENTE	Rug	180
ORIS	Bed	80
ORIZZONTE	Console	72
ORSON	Modular system	24
OTTO	Chair without armrests	46
PABLO	Rug	180

RANGE	CATEGORY	PAGE
PAGE	Rectangular dining table	52
PALADINO	Table lamp	147
PAMELA	Floor lamp	141
PAMELA	Table lamp	146
PARADE	Rug	181
PARIS	Small table	66
PASCAL	Armchair	37
PAUL	Armchair	36
PEGGY	Chair with armrests	41
PHILOSOPHER	Rug	182
PICNIC	Lantern	158
PLANET	Round dining table	54
PLAY	Coffee/side tables	59
PLAY	Bookcases	92
PRESTIGE	Sideboard	100
PRETTY	Chaise-longue	33
PURFLE	Rug	181
PURO	Side table	65
RAMAGE	Floor lamp	140
RASHOMON	Mat	186
REA	Floor lamp	138
REA	Wall light	161
REAME	Rug	183
REBEL	Rug	182
RENOIR	Sofa	27
RETTA	Floor lamp	141
RIDGE	Mat	186
RIESLING	Bar cabinet	94

RANGE	CATEGORY	PAGE
RIMA	Chair with armrests	43
RIMA	Chair without armrests	47
RODEO	Footrests/stools	39
ROLAND	Bed	83
ROMA	Bed	82
RONDÒ	Armchair	34
RONIN	Screen	105
RONNIE	Table lamp	151
ROUSSEAU	Desk	89
ROXY	Stool	38
ROY	Mat	187
ROYAL	Bar cabinet in Limited Edition	11
RUSSEL	Bedside table	77
RYOKO	Bed	81
SAN FRANCISCO	Coffee table	68
SEINE	Set of consoles	68
SHARON	Sofa	30
SHARON	Armchair and footrest	31
SIBILLA	Lantern	159
SMART	Consoles	71
SMART	Chest of drawers	98
SOFIA	Chair without armrests	48
STENDHAL	Desk	91
TANYA	Rug	184
TAO	Rack	107
TATE	Rug	184
TAYLOR	Rug	185
TED	Small table	57

RANGE	CATEGORY	PAGE
TERENCE	Outdoor sofa	116
TERENCE	Outdoor modular system	118
TERENCE	Outdoor armchair	120
TERENCE	Outdoor footrest	121
TERRY	Outdoor small table	123
TERSILLA	Floor lamp	137
TESSA	Table lamp	149
THELMA	Outdoor chair	122
THOMAS	Outdoor rectangular dining table	124
THOMAS	Outdoor round dining table	125
TIMEA	Table lamp	150
TIMOTHY	Outdoor sunbed	126
TOKYO	Armchair	36
TOM	Outdoor mat	188
TOMMY	Small tables	66
TOPAZIO	Rechargeable Lantern	157
TOPAZIO	Wall light	160
TOQUINHO	Outdoor mat	188
TRAVIS	Rug	185
TRILLY	Lantern	159
TROCADERO	Rectangular dining table	50
TURNER	Outdoor coffee table	122
TUTANKHAMON	Rug	183
VALET	Set of coffee tables	58
VEGA	Console	73
VENUS	Console	73
VIRGOLA	Bookcase	93
VISO	Sofa and footrest	28

RANGE	CATEGORY	PAGE
VISO	Armchair	29
VISTA	Table lamp	151
VOLTA	Table lamp	157

This catalogue is for internal use only. Any reproduction of images and texts is forbidden without the explicit consent of Giorgio Armani.

All colours and textures visible in the pictures - including furniture, rugs, wallcoverings, fabrics and finishes - may not correspond to the real products. Woods and stones in particular could present some slight variations depending on the production lot. This feature must be considered a distinctive trait of the natural material used. Please always refer to our showrooms and official dealers for more information.

GIORGIO ARMANI
VIA BORGONUOVO 11
20121 MILANO ITALY
WWW.ARMANI.COM/CASA

© 2025 GIORGIO ARMANI

